

Smart Cornhole



*Department of Electrical Engineering and Computer Science
University of Central Florida
Dr. Lei Wei*

Group 10

Giovanni Lara Electrical Engineer giolara1994@knights.ucf.edu

Francisco De La Cruz Electrical Engineer delacruz16@knights.ucf.edu

Alex Lam Computer Engineer alexlam@knights.ucf.edu

Nihil Patel Electrical Engineer npatel35@knights.ucf.edu

Table of Contents

1.0 Executive Summary	1
2.0 Project Description	2
2.1 Introduction.....	2
2.1.1 Equipment.....	3
2.1.2 Gameplay	4
2.1.3 Scoring.....	5
2.2 Motivation and Goal	6
2.3 Objective.....	8
2.4 Requirement Specifications.....	8
2.5 House of Quality Analysis	9
3.0 Research related to Project Definition.....	12
3.1 Existing Similar Products and Projects	12
3.1.1 LED Cornhole.....	12
3.1.2 Cornhole with speakers	13
3.1.3 Self scoring bag toss	14
3.1.4 Intelligent Cornhole Board	16
3.1.5 Cornhole/Bags Electronic Scoring System.....	16
3.2 Relevant Technologies	17
3.2.1 Proximity Sensors	17
3.2.1.1 Inductive sensor	17
3.2.1.2 Capacitive Sensor	18
3.2.1.2 Ultrasonic Sensor	18
3.2.2 Load Sensor.....	19
3.2.3 Image Processing	19
3.2.4 Radio Frequency Identification (RFID)	19
3.2.5 Wireless Communication	20
3.2.6 Voltage Regulator.....	20
3.2.6.1 Linear Voltage Regulator	20
3.2.6.2 Switching Voltage Regulator	21
3.2.7 Battery.....	21

3.2.8 LED Display.....	21
3.2.9 Speaker.....	22
3.3 Strategic Components and Parts Selection	22
3.3.1 Wireless Communication Technology.....	22
3.3.1.1 Radio Frequency Identification	23
3.3.1.2 ID Innovations Readers.....	24
3.3.1.3 RT400 UHF RFID Module	25
3.3.1.4 SkyeReader SuperNova.....	25
3.3.1.5 SparkFun Simultaneous RFID Reader – M6E Nano	25
3.3.1.6 Comparing Radio Frequency Identifications	26
3.3.1.7 Radio Frequency Identification Cost.....	26
3.3.1.8 RFID Read Distance	26
3.3.1.9 RFID Power Consumption	27
3.3.1.10 RFID Final Decision	28
3.3.2 Microprocessor Units (MCU).....	28
3.3.2.1 Texas Instruments.....	29
3.3.2.2 MSP430FG6425.....	29
3.3.2.3 MSP430FG6426.....	29
3.3.2.4 MSP430FG5994.....	29
3.3.2.5 MSP430FG5989.....	30
3.3.2.6 ATMEGA 2560	30
3.3.2.7 STM32L072RBT6	30
3.3.3 Comparing Microprocessors	31
3.3.3.1 MCU Power Consumption	31
3.3.3.2 MCU Memory Size.....	32
3.3.3.3 MCU Clock Frequency	33
3.3.3.4 MCU General Purpose Input/Output	33
3.3.3.5 MCU Cost.....	34
3.3.3.6 Microcontroller Final Decision	34
3.3.4 Battery Packs.....	35
3.3.4.1 Battery Comparisons	36

3.3.4.2 Battery Pack Decision	38
3.3.5 Bluetooth Modules.....	39
3.3.5.1 Bluetooth Module Comparisons	39
3.3.5.2 Bluetooth Module Decision	40
3.3.6 LED Display.....	41
3.3.6.1 Comparing LED's	42
3.3.6.2 LED Final Decision	43
3.3.7 Minor Component Parts.....	43
3.3.7.1 LED Light Strips	44
3.3.7.2 MENZO LED Strip Lights	45
3.3.8 Xbee Shield	45
3.3.9 Voltage Regulator and Amplifier	46
3.3.10 Speakers	46
3.4 Printed Circuit Board	46
3.4.1 PCB Design Software	47
3.4.2 Materials in PCB	47
3.4.3 PCB Design Recommendations	49
3.4.4 PCB Thermal Management.....	50
3.5 Part Selection Summary	52
4.0 Standards and Design Constraints	53
4.1 Standards	53
4.1.1 IEEE 802.15.4 Standard	53
4.1.2 Power Supply.....	53
4.1.3 Range of Available Frequencies.....	55
4.1.4 IPC PCB Standards	55
4.1.5 NASA Soldered Electrical Connections	56
4.1.6 Lithium Battery Standards	58
4.1.7 Bluetooth Standards	59
4.1.8 UL 94 Standard for Tests for Flammability of Plastic Materials for Parts Devices and Appliances.....	59
4.1.9 Cornhole Approved Equipment.....	60
4.1.10 Design Impact of Relevant Standards	61
4.2 Realistic Design Constraints.....	62

4.2.1 Economic Constraints.....	62
4.2.2 Time Constraints.....	63
4.2.3 Environmental Constraints.....	64
4.2.4 Social Constraints.....	64
4.2.5 Political Constraints.....	65
4.2.6 Ethical Constraints.....	65
4.2.7 Health Constraints.....	65
4.2.8 Safety Constraints.....	66
4.2.9 Manufacturability Constraints.....	67
4.2.10 Sustainability Constraints.....	67
5.0 Project Design Details.....	69
5.1 Microcontroller Details.....	69
5.2 Power System.....	69
5.2.1 Power Details.....	72
5.2.2 Power Distribution.....	73
5.2.3 USB Power Port.....	73
5.3 Wireless Communication.....	73
5.3.1 ZigBee for Wireless Communication.....	73
5.4 RFID Specifications.....	76
5.5 Display.....	80
5.6 LED's.....	81
5.7 Console Hardware Design Details.....	81
5.7.1 Console Microcontroller.....	82
5.7.2 Console Wireless (ZigBee).....	82
5.7.3 Console Button.....	83
5.7.4 Console Power.....	83
5.7.4.1 USB Power Port.....	83
5.7.4.2 Battery.....	83
5.8 Hardware Schematics.....	84
5.8.1 MCU with RFID Reader and ZigBee Schematic.....	85
5.8.2 Module MCU with ZigBee Schematic.....	87
5.9 Software Design.....	89
5.9.1 Design Methodology.....	89

5.9.2 Development Tools	90
5.9.2.1 Integrated Development Environment	90
5.9.2.2 XTCU.....	91
5.9.3 Microcontroller Development.....	92
5.9.4 RFID Development.....	95
5.9.4.1 RFID Development.....	96
5.9.5 ZigBee Network Development.....	96
5.9.6 Console Development.....	98
5.9.7 Display Development	100
5.9.8 Display Development	100
5.10 Summary of Design	102
6.0 Subsystems Testing	104
6.1 Arduino MEGA 2560 Testing	104
6.2 XBee 1mW Wire Antenna Testing.....	105
6.3 Simultaneous RFID Reader - M6E Nano	106
6.3.2 Simultaneous RFID Reader - M6E Nano With Different Aluminum Layers	107
6.4 LM1084 Voltage Regulator Testing	108
6.5 Seven segment display, Tri-Color Testing.....	109
6.6 Decoder Testing	110
6.6 RN-52 Bluetooth Testing	111
6.7 LED- Strip Testing	112
7.0 Project Prototype and Coding.....	113
7.1 Prototype Testing	113
7.2 PCB Design Prototypes.....	117
7.3 Final Coding Plan.....	118
7.3.1 Initial Heading	118
7.3.2 Setup Function.....	119
7.3.3 Loop Function	119
7.3.4 ReadTags Function	119
7.3.5 SortTags Function.....	119
7.3.6 IsGood Function.....	119
7.3.7 DoScore Function	120

7.3.8 DoXbee Function.....	120
7.4 Major Hardware Components	120
8.0 Administrative content.....	122
8.1 Milestone Discussion.....	122
8.2 Budget Discussion.....	123
8.4 Project Design Problems	124
8.4.1 ATMEGA 2560 CHIP Soldering Problem	124
8.4.2 Bluetooth Speaker Noise Problems.....	125
8.4.3 Software Development Problems	125
9.0 Conclusion	126
10.0 Team Description and Delegations	128
11.0 Appendices	130
11.1 References.....	130
11.2 Copyright Permissions.....	132

Table of Figures

Figure 1: Cornhole Board and Bags	3
Figure 2: Cornhole Dimensions.....	4
Figure 3: cornhole gameplay	4
Figure 4: House of Quality for Smart Cornhole.....	10
Figure 5: LED Cornhole.....	12
Figure 6: Bluetooth Speaker Cornhole.....	13
Figure 7: Self-scoring bag toss.....	15
Figure 8: Intelligent Cornhole Board.....	16
Figure 9: Comfort Zone Requirements. Permission submitted to use.....	57
Figure 10: Power system of the Smart Cornhole	70
Figure 11: LM1084 Schematic with Formula. Permission Granted Courtesy of Texas Instruments.....	71
Figure 12: Xbee Configuration	75
Figure 13: Xbee module	76
Figure 14: RFID Tags (Same tags programmed for different teams)	78
Figure 15: Effects of Foil	79
Figure 16: RFID Reader detection.....	79
Figure 17: Ideal 7-Segment Display Setup	80
Figure 18: Console Hardware.....	82
Figure 19: MCU with RFID Reader Schematic	86

Figure 20: Module MCU with ZigBee Schematic	88
Figure 20: Firmware for XBee.....	92
Figure 21: Main Gameboard Software Flowchart	94
Figure 22: Xbee module written values	98
Figure 23: Console Software Flowchart.....	99
Figure 24: Pin setup for 7-segment displays	100
Figure 25: Breadboard Prototype testing.....	116
Figure 26: Bluetooth Module Prototype PCB.....	117
Figure 27: Game board Prototype PCB.....	118
Figure 28: All Major Parts	121

Table of Tables

Table 1: Scoring Method Cornhole.....	5
Table 2: Cancellation Scoring of Cornhole	6
Table 3: RFID Comparison.....	27
Table 4: RFID Power Consumption Comparison.....	32
Table 5: MCU Comparison Table	34
Table 6: Battery Comparisons.....	37
Table 7: Bluetooth Module comparisons	40
Table 8: LED comparisons.....	43
Table 9: Part Summary	52
Table 10: Power Supply Specifications	54
Table 11: Estimated Component Power Draw.....	72
Table 12: 1mW Xbee Series 1RF Module	74
Table 13: ThingMagic Nano.....	77
Table 14: Battery Draw.....	84
Table 15: Relative Signal Strength vs Distance	96
Table 16: Console Switch Actions	99
Table 17: 7-Segment Decoder Decoded.....	101
Table 18: 7-Segment Decoder Input Truth Table.....	101
Table 19: Xbee test.....	106
Table 20: RFID Signal Strength Test.....	107
Table 21: 16 M6E Aluminum Layers Test.....	108
Table 22: Voltage regulator RFID and microcontroller test.....	109
Table 23: Voltage Regulator Xbee and Bluetooth test.....	109
Table 24: Voltage Regulator Seven Segment display test	109
Table 25: Decoder Testing 4 Input 7 Output	110
Table 26: Timeline.....	122
Table 27: Budget.....	123

1.0 Executive Summary

Have you ever had an argument with your friends, family members or significant other over the score while playing Cornhole? Have you ever had trouble counting or keeping the score while playing Cornhole? Now, there is a solution to that problem Smart Cornhole. Smart Cornhole will avoid cheating and wrong calculation of scores. It will also have wireless speaker and smart battery added to system to maximize the fun of our beloved cornhole game.

Cornhole is a very popular game of fun and family bonding, however the score keeping is outdated and even break up longstanding friendships. Currently the players are required to the keep score manually. This can be often performed incorrectly or a malicious player may try to artificially increase their score.

This project is to design a Smart Cornhole system that can mainly provide an automatic score detection and a keeper system for the game. A smart bright LED seven segment is added to system for the display of the score which is visible in the day light. In addition, wireless speakers will be added to the system which is universally desired by players of the game while they wait for their turn. Furthermore, LED lights will be added to system to enhance the dashing look of the Smart Cornhole.

The device will have a soft-reset switch on side of board to restart/reset the display for new players to start the game. A push- button will be used to switch teams after bags are thrown. The scoreboard will be synchronized wirelessly to keep both scoreboards displaying the correct score and at the same time update the score when more points are scored.

The device will be supplied from the rechargeable battery, since the cornhole is an outdoor game. Furthermore, the battery will be detachable from the board itself, to provide the ability to charge the battery without having to move the whole board near a power supply.

Smart Cornhole is not necessarily designed to inherent the market value, however the primary goal behind is to apply our academic skills. The design team wanted to have fun with the project but also deliver understanding of integration across various subsystems. This project is a proof-of-concept that our project has potential to extend into the digital era that will live in now.

2.0 Project Description

The following segment provides a generalized description of our project idea of smart cornhole. It explains the detail information about the history, equipment, gameplay, scoring and project motivation. It also as an additional information about requirement specification to achieve our project goal.

2.1 Introduction

Sports have been around the planet earth for very longtime. There is a great saying in Latin "*Mens sana in corpore sano*" which translates to "a sound mind in a sound body". The saying is often used to emphasis that physical activity is an important and significant part of healthy lifestyle. A Sport is a physical activity, which is overseen by set of rules and regulations with no pre-scripted plot of the results. It can be performed on land, in air and water. It requires physical strength or mental strength or both.

Sports like football, soccer, cricket, basketball, and baseball to name a few are the most popular sports around the world. All these sports not only give physical strength but also a great mental strength as well. It creates sensations and excitement for both players and spectators. Since sports are not scripted, it creates suspense and thrills not only for a player but also for spectators as well. Spectators gather in large crowd to watch these amazing sports performed by players.

When spectators often gather in larger groups for these social events they often strive for entertain, socialize, and feast together. These social event is called Tailgating, which is originated in our United States of America. Tailgating is event which involves the consumption of beverages, grilling foods, and lawn games. It is often organized outside of arena in parking lots. Believe it or not tailgating is an important and as entertaining as sports in arena.

Tailgating games or lawn games are associated with tailgating because they are fun and simple to play. The games like Cornhole, Kanjam, Horseshoe, Beer-pong, and Flip-cup to name a few are widely enjoyed by the people. Music is also a big part of any social event. People often bring their stereo equipment to an event to enjoy good music and dance. As a college student attending tailgating events was one of most memorable and enjoyable time of my life. As for me, out of all the tailgating-games cornhole was one of the most fun and exciting games. Cornhole is widely enjoyed and beloved tailgating-game around America. Cornhole is a lawn game which involves two players or four players tossing the bag filled with corn at raised at an angle of wooden board with a hole in the far end. Since the bag is filled with corn, hence the name "Cornhole". It rose in Cincinnati

throughout the late nineteen nineties, spreading across the United States rapidly. The game activity involved throwing the finished corn cobs into the trash can. The figure 1 below represents the Cornhole board and bags.



Figure 1: Cornhole Board and Bags

Although, there are several different originations stories of this sport, it is believed that Blackhawk Native American tribe who filled dried beans in a pig bladders tossed them competitively for entertainment. They would keep scores by mentally remembering who would throw the farthest. The other version of story claims that game was originated in Germany in fourteenth century, and then it was rediscovered in hills of Kentucky over hundred years ago.

The game has improved throughout the past few years; however, the scoring guidelines of the game have not changed much. As for now, the truth about the origin of the game can be ignored because the game is simple and fun. This game is friendly to players of all ages and skill levels, and has the versatility to played in almost any place; parks, backyards, beaches, schools, and parties.

2.1.2 Equipment

Cornhole game play is simple and easy to follow. First, let's talk about the required equipment's for this fun game which is established by American Cornhole Organization. The game utilizes two boards which have the following dimensions: two feet by four feet (2ft x 4ft) with a six-inch (6-in) diameter hole in the upper center region, nine inches (9-in) from the back of the board and one foot from either side; going from one-foot-tall on the back to zero in the front. The boards are separated by twenty-seven feet (27-ft), from the front of each board. Since it is a game for mostly all ages it can also have less than twenty-seven feet distance

for younger players. The figure 2 represents the visual dimensions of constructions of cornhole.

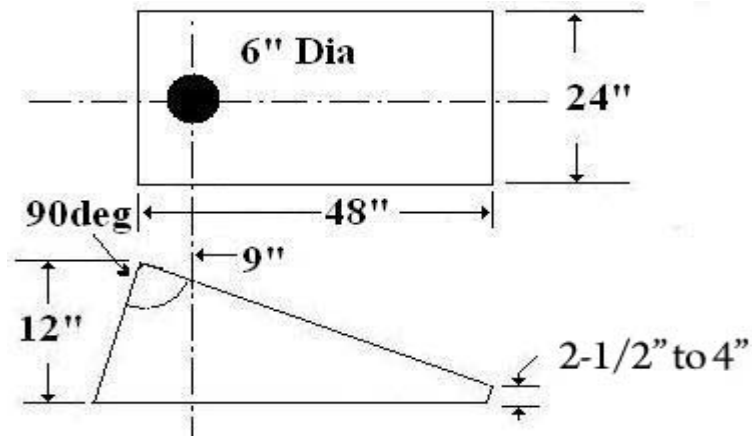

Figure 2: Cornhole Dimensions

There is a total of eight bags, with four bags per team. The set of four bags are identifiable or usually two separate colors to represent each team. Each bag is filled with corn kernels. The measured bag is six by six (6in x 6in) and they weigh in between fifteen ounces(15-oz) to sixteen ounces(16-oz).

2.1.3 Gameplay

Second, let's talk about the gameplay. The gameplay is simple to follow. There are two teams made up of two players or one player each. These players are often referred to as pitchers since they are tossing or throwing the bag. The game is played with two sets of bags, two cornhole boards and two to four players. The bags can be thrown either right or left side of pitcher's box. The pitcher's box is a rectangle areas of four by three feet (4ft x 3ft), which is exactly parallel and on both sides of cornhole boards. Each player must remain in the area while pitching the cornhole bags. The bottom of the cornhole is considered foul line. Pitchers should not step over the foul line while pitching. The figure 3 below represents the distance and basic location of players.

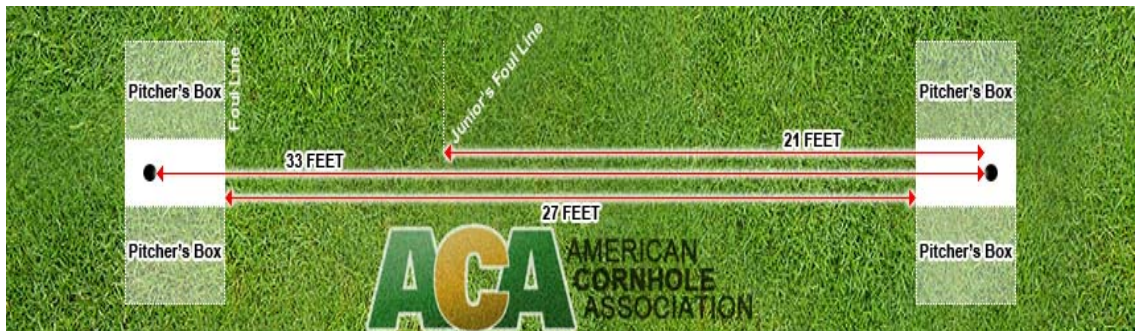

Figure 3: cornhole gameplay

The game can be broken down into two innings of play. During each inning the players will throw four bags each. An inning is never completed until all players throws all four bags. Since it can be played with singles and doubles, let's talk about singles pitchers first to avoid the confusion.

In Singles, two players compete against each other. They also pitch from the same cornhole board. The first inning is completed when the first player pitches all four bags, and the second inning is completed when the second pitcher tosses remaining four bags. In doubles, there are four players, they partner up against another team of two players. There are still two innings. The game play of the first inning is completed when one member of each teams pitches all four bags form the same side of cornhole board. The second inning is completed when the other two players pitch all four bags from the other side of the cornhole board.

2.1.4 Scoring

Third, let's talk about the scoring. The scoring can be bit confusing. Landing a bag on the surface of the board scores one point to the designated team, and making the bag in the hole scores three points to the designated team. A bag failing to land in the hole, or on the board at all, scores zero. There are different versions of scoring like simple scoring and cancellation scoring. A simple scoring works this way let's say there are two teams of doubles red and green. In this scenario first innings of doubles have finished throwing all their bags, where bags of red team have landed one in hole, one on the board and the other two on ground. The bags of green team have landed one on the board, two in hole and last on the ground. Total score of red team is four and green team is seven. The process repeated until team reaches exactly twenty-one. The table 1 below will represent the scoring of two innings.

Table 1: Scoring Method Cornhole

Bags	Red team	Green team
1 st bag	3	1
2 nd bag	1	3
3 rd bag	0	3
4 th bag	0	0
Total score of 1st Inning	4	7
1 st bag	1	1
2 nd bag	1	0
3 rd bag	1	0
4 th bag	1	0
Total score of 2nd Inning	8	8

A cancellation scoring works this way, let's say there are two teams of doubles red and green. In this scenario first innings of doubles have finished throwing all their bags, where bags of the red team have landed one in hole, one on board and other two on ground. The bags of the green team have landed one on the board, two in the hole and last one on the ground. Total score of red team is four and green team is seven, since it is cancellation scoring red score will be subtracted from green team which higher score, leaving final score for green team to be three and red team score is zero. The process is repeated until team reaches exactly twenty-one. To win the game, a team must score exactly twenty-one points, no more, no less. If the team goes over twenty-one it resets the score back to the last known score of the team. As for a lot of people, game play is simple but overall keeping the score is complicated. The table 2 below will represent the scoring of two innings.

Table 2: Cancellation Scoring of Cornhole

Bags	Red team	Green team
1 st bag	3	1
2 nd bag	1	3
3 rd bag	0	3
4 th bag	0	0
Total score of 1st Inning	0	3
1 st bag	1	1
2 nd bag	1	0
3 rd bag	1	0
4 th bag	1	0
Total score of 2nd Inning	3	3

2.2 Motivation and Goal

One of the main problems while playing the game, is that since no one takes time to write down or keep track of the scores, dishonest players may try to cheat by lying and boosting their scores to gain an unfair advantage. So, while players are having a great time playing, a malicious player may try to artificially increase their score. This can lead to arguments happening between the teams, causing the game to end prematurely, and even break longstanding friendships between the players.

The way our team wants to improve the game, is by adding an automated bag detector and score keeper. Using sensors to detect bags on the board, the microcontroller will keep track of any bag that would land on the board. The microcontroller will then process this input, and update the scoreboard. The scoreboard will remain fixed after the first inning is over and the bags are removed from the board, and then proceed to the next turn. A display will be implemented into the design, which will display the score to both teams. The scoreboard will

be synchronized wirelessly to keep both scoreboards displaying the correct score and at the same time update the score when more points are scored.

Cornhole can become rather boring while the player is waiting for their turn, therefore, we propose the addition of wireless speakers to the cornhole board. Players will be able to listen to their favorite music and even dance while they're playing the game. The idea is to implement speakers in each cornhole board, allowing the players to connect their smart phones and play their favorite music while playing cornhole. The speakers must be chosen carefully, keeping two main concerns in mind: power efficiency and loudness. Concerning power efficiency, the battery should be able to power both the speaker and the microcontroller unit for a few hours to allow the users to play many rounds of the game. On the other hand, the speaker needs to provide a decent amount of loudness, since in most cases, users play the game in places with loud background noise. This will allow the speaker to be heard clearly by both players around the cornhole board in all of the various settings and scenarios.

The fact that Cornhole is an outdoor game, brings up the use of a battery to power all the components that make up this advanced version of the game. The biggest issue is that there isn't a normal AC wall plug available at most places where the game is played. Even if there was a wall plug, there would be a need of an extension cord to reach both Cornhole boards. A battery for each cornhole board solves this issue with a portable power source. The battery will allow users to play in any place, as well as being versatile in more environments, and offer greater mobility. Each of the batteries should be able to last for a decent amount time while playing Cornhole and listening to music through the wireless speakers. Furthermore, the battery should be able to detach from the board itself, to provide the ability to charge the battery without having to move the whole board near a power supply. It should also allow the players to charge the battery during a game of cornhole to provide a longer usage.

There will be a simple on/off switch to turn on power to the board after the battery is plugged in. We would like to take it a step further on show, and light up the board with LED lights to improve the overall attractiveness. There will be soft-reset switch on side of board to restart/reset the display for new players to start the game. A push- button will be used to switch teams after 4 bags are thrown. The challenging part about this project is how we will accurately detect score. After much discussion and research on our idea we came up with the ideal method for detecting score. We went through multiple ideas to detect scores such as weight sensors, cameras, or RFID sensor systems. Each approach has its advantages and disadvantages.

2.3 Objective

The main objective of this project is to design an automated scoring system for cornhole. In which players will be able to enjoy the game without keeping track of their own score. This will avoid cheating and wrong calculation of scores. The design will have wireless speaker and smart battery added to system to maximize the fun of our beloved cornhole game.

2.4 Requirement Specifications

The requirement specifications below will ensure that the design of the Smart Cornhole meets certain requirements to ensure a superior quality design is implemented. These requirements specifications will provide the designers a challenging project to gain experience for future endeavors, while still implementing a high-quality product.

- Score Detection
 - The system shall have a wireless reader under the board to detect bags that land on the board.
 - The system shall provide an accurate reading of a three-point throw.
 - The system shall determine the score from independently from the different teams.
 - The system shall perform point calculations after each turn.
 - The system shall have a microcontroller unit to receive inputs and send outputs to/from different components.
- Score Board
 - The score board shall be big enough to be seen while standing above the board.
 - The score board shall update after every turn.
 - The system shall announce a winner after reaching to twenty-one points.
 - The system shall be reset after each game.
- Power Supply
 - The system shall be powered through a battery.
 - The batteries shall be able to last a decent amount of time.
 - The batteries shall be rechargeable.
 - Batteries shall be able to detach from board.
- Speakers
 - Speakers should have wireless Bluetooth connection capability.
 - Shall have good connectivity range.
 - Be loud enough to be heard by both nearby players.
 - Speakers shall be able to connect to any Bluetooth enable device.
- Board Dimensions
 - The system needs to be four feet long.
 - The system needs to be two feet wide.
 - The system must be two to four inches off ground in the front.
 - The system must be one-foot-tall in the back.

- The hole must be placed 6 inches from the top and one foot from either side to the center of the hole.
- The hole must be six inches in diameter.
- The whole system must not weight more than five pounds.

2.5 House of Quality Analysis

The house of quality shown in the following figure, is a visual tool that enables the designers to see the relationships between the Marketing and engineering requirements. These requirements will ensure a product that is more attractive to potential customers, while meeting the engineering requirements to ensure the maximum market potential. This house holds seven categories for marketing and seven for engineering with many being positively related to each other. These categories are there to create the perfect mixture between what the engineer wants to accomplish and what the consumer wants to persuade them to purchase a Smart Cornhole.

The house of quality ensures that a new product being design meets certain requirements based on the needs from potential customers. These marketing requirements will ensure the Smart Cornhole design will be attract customers to purchase it. These requirements include the portability, right size, ease of use, lifetime, cost, wireless range, and battery life. Customers will always want to purchase a product at the lowest possible cost, which is why cost is such an important piece within the design itself, due to the fact that it can set the decision of the customer to whether or not purchase the product. A product having good portability can attract some customers, since a product that needs to be move to be used (to play outdoors), portability can definitely be a desired requirement. Cornhole can really be made in any size, but following the official dimensions set by the American Cornhole Organization (ACO) will ensure potential competitions based customers will consider this new cornhole design to be used in their competitions. The ease of use is another important market requirement, since this cornhole is played by people of all ages, it should be designed with a simple method and fast technique of being able to set it up to play. In addition, if the design is simple enough that any young person is able to set it up without any complications, this will ensure the design attracts customers in all ages due to its simplicity and portability. The lifetime of the smart cornhole is another important requirement, which will provide a design with better components to provide the customer with a longer lasting system. If a good lifetime isn't achieved the reputation of the design can decrease. The future sales of the system making the lifetime an important requirement to follow. The battery life and wireless range are another two important requirements, due to providing a better performance of the whole system. These market requirements discussed will ensure the design will be purchased by customers.

			Engineering Requirements					
			1) Quality	2) Power	3) Weight	4) Dimensions	5) Efficiency	6) Cost
			+	+	-	+	+	-
Marketing Requirements	1) Portability	+			↑↑	↓		
	2) Right Size	+	↑		↑			
	3) Ease of use	+						
	4) Lifetime	+	↑↑	↓			↑	↑
	5) Cost	-	↑↑			↑	↓	
	6) Wireless Range	+		↑				↑↑
	7) Battery Life	+	↑	↓	↓	↑	↑↑	↑
Targets for Engineering requirements			Up to Standard	<1.5w	<5 lbs	24 X 48 inches	> 50%	<\$500

Figure 4: House of Quality for Smart Cornhole

Below is the key to what every symbol means in the house of quality.

- ↑= Positive Correlation
- ↑↑= Strong Positive Correlation
- ↓= Negative Correlation
- ↓↓= Strong Negative Correlation
- + = Positive Polarity (positive effect on project quality)
- = Negative Polarity (negative effect on project quality)

The engineering requirements is another list of the system, but this time its done in the designer's point of view instead of the customer's. The engineering requirements that apply to the Smart Cornhole are quality, power, weight,

dimensions, efficiency, and engineering cost. The better the quality of the entire system, the more it will cost to make and the longer life span the components will have. The more power the system uses, the lifetime will decrease since components use at its maximum potential which usually breaks down faster; the battery life will decrease as well since the more power is used the faster the battery drains, which can lead to selecting one with more capacity. On the other hand, the system can perform better with more power, giving a better range to the wireless system. The weight of the system can affect a few marketing requirements, if the weight decreases then the portability should increase, since the system will be lighter to carry around. Moreover, the weight will increase with a higher capacity battery and with the official dimensions used in competitions. Next is the dimensions of the whole system, if portability increases it will decrease due to the system taking more volume. On the other hand, the battery life and cost will increase, since it will require more material to build and more room to store a higher capacity battery. To provide a more efficient system, better quality components that are needed, which is why the cost will increase. Overall, the efficiency will also waste less power resulting in better battery life. Finally, the engineering cost of the system can increase if a higher capacity battery is used, a better performance wireless communication is implemented, and with components that can ensure a longer lifetime for the system.

Finally, the bottom row represents the targets set by the engineers to accomplish in this specific design. These targets are set to ensure the design will have a good overall quality based on realistic goals. Some of these goals might not be met by the final design, but the designers will try to meet every single one of them to provide the market a more attractive design for the customers.

3.0 Research related to Project Definition

The first step to design any project is research. This section provides detail information on existing projects, relevant technologies, part selection, and related design. The perfect upgraded cornhole has not been created yet. Our sources for research will consist of different university projects, articles, and any other related products and projects. By doing extensive research on a cornhole, will help us to implement a successful final product. This section will serve a vital role to our project. It will explore each area of design that must be taken in consideration to help us create smart, new, and improved cornhole.

3.1 Existing Similar Products and Projects

Cornhole has been around for a longtime. The market has developed many different versions of this product which is relevant and fun. Below we will compare and describe several different projects and products of cornhole. Furthermore, there will be brief information of the technology used behind each product or project cornhole.

3.1.1 LED Cornhole

First, let's talk about the LED cornholes. This is one of the basic version of cornhole and yet a fun product. It has several different versions on the internet for this product. It is basically illumined with LED lights powered by the battery source on a cornhole board and bags. There are several uses of this project, such as it can be enjoyed during the late-night events or just late night boredom. This product is available for purchase on the internet ranging from \$15 to \$200 plus. The figure 5 below represents the LED illumined cornhole.



Figure 5: LED Cornhole

The technology behind this product is LED lights. A light emitting diode (LED) is a two-lead semiconductor light source, which emits a visible light when an electric current pass through it. It is a p-n junction diode. It appeared in 1962 with low-intensity light. A modern led light has revolutionized our world with brighter, efficient and long lasting than incandescent bulbs or compact fluorescent lights(CFL). They last anywhere from twenty thousand (20,000) to fifty thousand (50,000) hours to any comparable bulbs available for purchase in the market. Like any efficient and durable product comes with a higher price tag but cost have significantly reduced over the years. They once costed anywhere from fifty to hundred dollars now they cost around ninety-nine cents to ten dollars depending specification. It produces little or close to no ultra violet emissions. It is operational in extremely hot or cold temperatures. It can be dimmed, which results in control of light and color. It is ecological friendly which means it is hundred percent recyclable and toxic free. Early LED lights were used as lamps for electronic devices, now their uses have gone above and beyond. They are now used in portable devices such as cameras, cellphones, and televisions are some electronics. All these benefits often come with few disadvantages. They often cost most per lumen which implies higher initial capital cost. They are highly voltage sensitive. Since, there are more advantages than disadvantages it is highly popular and valuable product in our day to day use. Our project will include LED lights because of its advantages and external show of the cornhole board.

3.1.2 Cornhole with speakers

Second product, I would like to discuss is a built-in Bluetooth speaker in cornhole board. This brings the entertainment to the next level. This product advertises itself, it has additional two built in Bluetooth speakers to the back of your cornhole set. This product is available for purchase on internet ranging from \$65 to \$200 plus. Each player now can enjoy their own music on their own side of the cornhole board. The figure 6 below represents built in Bluetooth speakers on cornhole.



Figure 6: Bluetooth Speaker Cornhole

The built-in Bluetooth speakers can be paired with iPhone or android devices. It supports new Bluetooth v3.0 technology. They are highly powerful 40mm total six watt acoustic drivers and ultra-small size product a wide audio spectrum. It has built in Li-lion rechargeable battery for up to ten hours of playtime. The benefits this project is add more entertainment to every tailgate and party we attend. Music helps us to unwind our day-to-day stressful life. Let discuss the technology behind this product. It simple uses Bluetooth enabled speakers, powered by battery. Bluetooth is the foundation for transformative wireless connectivity, which means instead of using wires or cable it uses radio waves to connect. It was invented in 1989 by Nils Rydbeck, which has revolutionized the present day wireless technology standard for exchanging data over short distance. It has a tiny computer chip with a radio and software, which makes it is easy to connect. The communication between two devices is carried by pairing with each other. This communication is known as piconets. A piconets is a network of devices is connected using Bluetooth, in which the network is established one devices takes the role of master while all the other devices act as slave. It is connected and disconnected as the device enters and leave the proximity. The most popular application is wireless audio, which lets user to connect in cars, wireless speakers and headphones from their handheld devices. Due to its low energy functionality it can last for months, and in some cases for years. Hence, this technology can be found in billions of devices from phones to the shoes we wear. It is wireless, cheap, and low energy consumption. It is used worldwide and upgradeable. It is automatic, which means does not need a push button. It typically can connect in less than 10m all the way up to 100m. All these benefits often come with few disadvantages, they are short range technology and are not particular to high bandwidth range. Since, the more advantages than disadvantages it is highly popular and valuable product in our day to day use. Our project will include built in Bluetooth speakers because of its advantages and entertainment outlook.

3.1.3 Self scoring bag toss

This project was accomplished by senior students of University of Notre Dame in 2007- 2008. Their team designed a new electronic scoring game based on cornhole, which is like cornhole but have different set of scorings and detecting bags in hole. It is relevant to our project because it is an automated scoring system. A box is made of wood and angled at a slope, featuring six hole in a triangle formation, which can be describe a collaboration of beer pong and cornhole game. The gameplay was described as players would stand approximately thirty feet away to accumulate a point for each hole. A team will get a point each time they pass a bag through the hole. Another point will be added if they hit again. However, if they hit same hole twice no score is rewarded. Once, the player hits all six holes the winner is declared. In order, to help the player to keep track of which hole has been hit, the LED lights around the hole

will turn off after it has been hit by a player. Each board has two sets of display to keep track of number of games each team has won. The figure 7 below represents their project.



Figure 7: Self-scoring bag toss

To accomplish this project, they used six light sensors per boards and bean bags. It uses phototransistors and LEDs to determine whether a bag in the hole. It is accomplished by using an integration of variation technologies, in which at beginning of the game, the lights around each hole are lit. When the player hits the hole, the bag covers the lights from the LEDs to the phototransistors. The microprocessors then detects change in the voltage and finally turns off LEDs lights and that will increment the score on the display. In addition, the user inference is included in the system with on, off and reset switch. Their project includes five main subsystems to work together to achieve this working solution. It includes sensing, display, communicating, power and user interfaces. The input and output are interconnected which allows this system to function correctly. The sensing subsystem uses phototransistors to detect covered hole. Their power source includes twelve volts' battery and voltage regulators that supply the necessary powers to various parts on the board. The main concept behind this project is phototransistors or photodiode is a device that converts the light energy into electric energy. In other words, it produces a small voltage or current when no light is present. It is a bipolar device that is made of silicon or semi conductive material and is dependent on light energy. They are relatively inexpensive, simple and small enough to fit on a single integrated computer chip. They are fast and capable to produce almost instantaneous output. They are widely used in any electronic devices that senses light. They are also used in smoke detectors,

infrared receivers and Cd players. Overall, the project is highly informative to our research. Since, it changes the concept of cornhole which create a conflict of view with our total project goal.

3.1.4 Intelligent Cornhole Board

This project was accomplished by senior students of The Citadel college in 2012. Their team designed a fully functional automated scoring cornhole system. Their project takes in consideration of basic rules and concept of cornhole scoring. Their project was engineered to electronically score the game by image processing, radio frequency identification(RFID), Bluetooth communication, and programming to calculate, transmit and display the score on a smart phone. The figure 8 below represents their project.

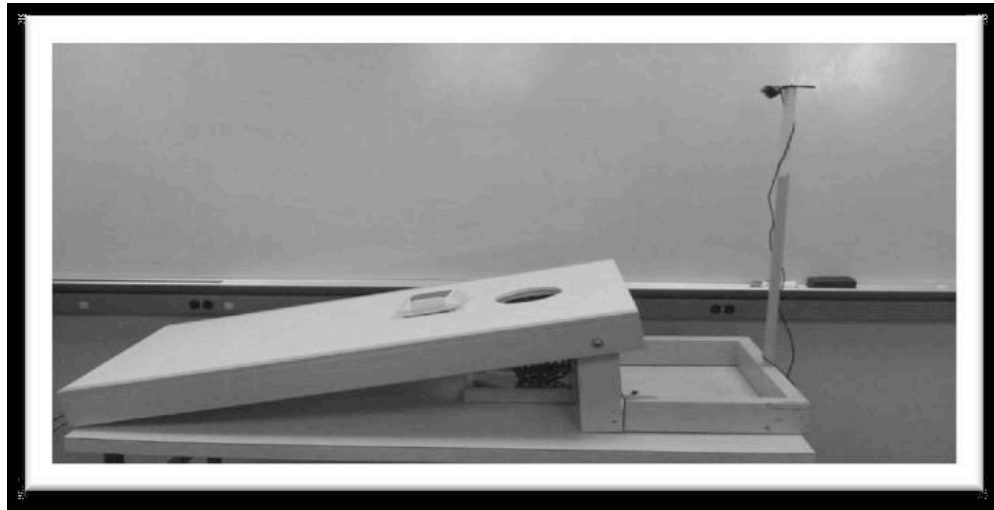

Figure 8: Intelligent Cornhole Board

To accomplish this project, they used image processing which captures the images on the boards surface of bags. The RFID identifies each bag as it hits the hole. The Bluetooth communicates and displays the correct score on the mobile device. Overall, the project is highly informative to our research. Since, it is design would not fit for commercial use and our expectation we will not use image processing technique.

3.1.5 Cornhole/Bags Electronic Scoring System

This project was accomplished by senior students of University of Illinois in 2012. Their team designed a fully functional automated scoring cornhole system. Their project takes in consideration of basic rules and concept of cornhole scoring. Their project features electronic scoring. It has capacitive sensor to detect one teams bag and inductive sensors to detect team two bags through the hole. It

also has LEDs to light up indicating bag going through the center of hole. The score is updated after each sides of players has thrown their set of bags. Communication between both boards have established to output score. They have also used four distinct RFID tags to differentiate the scoring. There is a switch for users to store the previous rounds score and start the next round. Their main goal of project is similar goal to our project is to avoid manually keeping track of scoring rather than enjoying the game. The main technology behind is RFID. It is the best way to successfully implement our project. RFID stands for Radio-Frequency Identification. The acronym usually refers to small electronic devices that consist of a small chip and an antenna. It is commonly used to transmit and receive information. This technology is widely used in manufacturing, retail, clothing, to name a few. Overall, the project is highly informative to our research. Since, the benefits of The High Frequency RFID reader are seems to be the biggest component of our project it will be included in our project.

3.2 Relevant Technologies

There are many relevant technologies in the market now that can help us create our smart cornhole. This section will cover the board research done in each method that we will be or can be used for our project. Thus, there are different technologies like sensors, cameras, RFID, microcontrollers, and much more. The research done on different technologies will helps understand what is available in the market. The best options from the research will be chosen to make this project achievable. The research of different current technologies will allow smart cornhole to have best performance results.

3.2.1 Proximity Sensors

We live in an era, where we are surrounded by a lot of advanced technological devices. When we think about such devices, the word sensor often pops up in our head. A sensor is a device that converts real-world data into digital data that a computer can understand. Sensors are used everywhere and it has revolutionized the world we in live. With the help of sensors, we now have things like autonomous cars and planes. Autonomous objects are possible due to proximity sensors. Proximity sensor is a sensor that can detect the presence of surrounding objects without any physical contact. It often emits an electromagnetic field or beam of radiations, and detects the changes in the field or a signal. Below we will discuss a few relevant sensors that can help us to achieve our smart cornhole.

3.2.1.1 Inductive sensor

An inductive sensor is a one type of proximity sensor that is used to detect the position of metal a object. It is based on Faraday's law of induction. It is a type of

non-contact electronic proximity sensor that is used to sense the location of metal objects. The sensors consist of a coil, oscillator, and detector where the output circuit is used to detect metallic targets. The way it works is, the coil generates a high frequency magnetic field, and when metallic target is in proximity the object will absorb some of its energy. This will affect the oscillator field, and the object is detected once the oscillations amplitude attains a specific value. The sensing range of the detection varies on the different types of metal. Metals like iron and steel have longer range, while on the other hand aluminum and copper can reduce the sensing range up to sixty percent. They are highly accurate compared to other proximity sensors. Another great advantage is they have high switching rate. Furthermore, they can work in harsh weather conditions. The common uses of inductive sensors are metal detectors, traffic lights, car washes, are to name a few. Due to better and other efficient technology available in market, we decided not to choose this technology. Due to better and other efficient technology available in market, we decided not to choose this technology.

3.2.1.2 Capacitive Sensor

A capacitive sensor is a one of proximity sensor that is used to detect the position of metals, nonmetals, solids, and liquids, although it is mostly suited for nonmetallic targets. The sensor consists of plate, oscillator, threshold detector and an output circuit. The way it works is the capacitive proximity generates an electrostatic field and reacts to changes in capacitance caused when an object enters the electrostatic field. When the object is outside the field, the oscillator is inactive. As the object enters the field, a capacitive coupling develops between the target and the capacitive probe. The capacitance reaches a specified threshold, oscillator is activated, triggering the output circuit to switch states between active and inactive. They can detect both metals and non-metals. Another great advantage is they are low cost and have good resolution, stability, high speed and low power usage. The common uses of capacitive sensors are used in touchscreens of electronic devices. Due to better and other efficient technology available in market, we decided not to choose this technology.

3.2.1.2 Ultrasonic Sensor

An ultrasonic sensor is also one of type proximity sensor that uses the sound waves to detect the position or measure the distance between object. The sensor receives and emits sound waves. The way it works is by sending out the specific frequency and listening for that sound wave to bounce back to measure the distance. They can detect various objects over the distance of several feet. Another great advantage is they can function in adverse climates. The common uses of ultra-sonic sensors are humidifiers, sonar, medical ultrasonography, burglar alarms, non-destructive testing and wireless charging. Due to better and

other efficient technology available in market, we decided not to choose this technology.

3.2.2 Load Sensor

A weight sensor or in other words load cell is a transducer that is used to convert mechanical signal to electrical signal as output, whose magnitude is proportional to the force being measured. There are various types of sensors like hydraulic, pneumatic, and strain gauge cells. Strain load cell is the mostly common and relevant to our project. When a force is applied to any stationary object, stress or strain is produced. Similarly, when cornhole bags hits the board it will converted to electrical signal and scores can be calculated by totaling the weight of bags. Since, complexity, and its highly inefficient, we decided not to use this technology.

3.2.3 Image Processing

An image processing is a technique to convert an image into digital image, to extract some useful information from it. It is a type of signal, where input is an image like video or picture and output is characteristic related to the picture or video. It usually treats image in two dimensional. It is one of the rapidly growing technologies today. Most of its research is related to engineering and computer science. The purpose of the image processing is divide into five parts. The visualizations, image sharpening/restoration, image retrieval, measurement of pattern, and image recognition. There are two types of method analog and digital image processing. Analog image processing can be used for like printouts and photographs, while digital image processing uses computer. They are widely used in intelligent transportation system, remote sensing, moving object tracking, and defense surveillance are to name a few. This is can be easily used in your project, by scanning the color of bags on the cornhole board and total up the score at end of each round. It has also been used is some of the previous projects. Using image processing technology can alter the design of board, which was not viable option for our team. so, we decided not to use this technology.

3.2.4 Radio Frequency Identification (RFID)

RFID stands for Radio-Frequency Identification. The acronym usually refers to small electronic devices that consist of a small chip and an antenna. It is commonly used to transmit and receive information. It uses tags or labels to identify objects. The tags can be passive, active or battery powered a passive. Active tag is always powered battery and it transmits its ID signal. Passive tag is cheaper and has no battery. It uses the radio energy transmitted by the reader. The functionality of RFID depends on three components, first a tag or label,

second a RFID reader and third an antenna. It uses electromagnetic fields to automatically detect and track tags attached to objects. The tag connects the electronic information. This technology is widely used in manufacturing, retail, clothing, are to name a few. It has also been used in past project to successfully implement automated cornhole without altering the design of board. Due to its long-range capability, low cost, and efficiency the RFID it will be included in our project.

3.2.5 Wireless Communication

Wireless communication is an exchange of data between two or more points connected by the electrical conductor. One of most common use of this technology is radio waves. The distance can be short or as far as deep-space. A data communications is one important segment of wireless communication. It allows the connection between various smart devices available in market, such as computers, cell phones, tablets, and other related electronic devices. Wi-Fi is one of the important wireless service available today. It enables the devices to connect with each other easily and effortlessly. It is wireless local area networking with devices based on the IEEE 802.11 standards. Most electronic devices sold today are equipped with wireless LAN technology. It is reliable and cost efficient. It eliminates wired Ethernet technology. Data transfer speed is way faster than ethernet cables. All these advantages come with little disadvantages as well. It is hackable and security is at concerns. Speed could be affected depending area of its location. Since, cornhole has two boards and they need to be in contact with each other for updated score, wireless technology will be included in our project.

3.2.6 Voltage Regulator

A voltage regulator is designed to regulate constant AC or DC voltage supply to electronic devices. It is found in almost every electronic device. It is useful device to us because most of electronic devices are made to receive the specific amount of voltage, if the voltage is not maintained it can seriously damage or blow up a device. It can include feed-forward or negative feedback depending on the design. There are two categories of voltage regulator: linear regulator and switching regulator. Since, our project includes different powered components voltage regulator will be used to maintain safe and steady power.

3.2.6.1 Linear Voltage Regulator

A linear voltage regulator uses an active pass method that is controlled by a differential amplifier at a high gain. The device compares the output voltage with a reference voltage and consequently regulates itself to compensate and continue a consistent output voltage. There are two type of linear voltage: series regulator

and shunt regulator. Back in days, vacuum tubes were used as resistance. Nowadays, it is designed with one or more transistors instead of tubes with integrated circuits. One of great advantage is it very clean output with little noise to output. They are best in use when low power level needs to be produced because they cost less and occupy less space in circuits. However, it less efficient and unable to invert input voltage. It requires higher input than the output.

3.2.6.2 Switching Voltage Regulator

A switching voltage regulator operates by translating DC input voltage and feeding back the filtered output voltage through a circuit that controls the device's power switch, turning it on and off in such a way as to control constant output voltage. They are best in power efficiency. They are required only to supply DC voltage and higher voltage is required. They are cheaper to produce. It can be designed with various switching frequencies, capacitor and inductors. It is more inclined to noise than linear regulator.

3.2.7 Battery

Battery is a container consisting of cells, in which chemical energy is converted to into electric energy and used as power source to electronic devices. It was first introduced in 1800s and it is still revolutionizing the modern age. It is two terminals positive is called anode and negative is called cathode. There are two type of batteries disposable and rechargeable. A disposable battery is single use battery meaning once it is used, it should be disposed/recycled. They are often alkaline batteries and used in toys, flashlights, etc. A rechargeable battery can be charged multiple times from the power supply of wall socket. They are often made of lithium-ion and used in cars, laptops, phones, etc. Batteries comes in different sizes which varies from small that is used to power headphones to mega batteries that is used to power large data centers. They can function in almost any weather condition. They can be used in remote places where there is no power supply. They are easy to replace. With the help of batteries, we are available achieve electrical cars and planes which are less injuries to environment. When there are lot of advantages there is also few disadvantage, like they highly dangerous. They can explode, cause fire and can lead to chemical pollution. They often require to be recharged. Since, our project portable and requires less power, a battery will be included in our project.

3.2.8 LED Display

A led display is a panel of a display, which uses a collection of LEDs as a pixel for a video screen. They can provide visual effects, stage lights, and other entertainment purposes. Their effective brightness allows them to be used at

outdoors as signs on bright day light. They are often used in the vehicles, store-signs, traffic signals, etc. Since, our project is usually used outdoor in bright day light, a LED Display screen will be added to the display scores.

3.2.9 Speaker

An electronic speaker is transducer, which converts electrical audio signal to the sound. It was invented by in 1925 by Edward W. Kellogg and Chester W Rice. They are a household item which is often made of wood or plastic. They are for home uses with three types of dynamic drivers which are mid-range driver, tweeter and woofers. High audio frequencies are referred as tweeters, those who are middle frequencies are referred as mid-range driver and for low frequencies are referred are called woofers. Speakers are often found in radios, televisions, computer and any electronic musical instruments. Since, our project is fun and challenging, speakers will be added to our system to enhance the entertainment side of our project.

3.3 Strategic Components and Parts Selection

The most important part to ensure that the “Smart Cornhole” is a success is of course the materials used to implement the design. In this section each material will be discussed in detail along with various others that were also considered but didn’t make the final cut. These products include but are not limited too: Radio Frequency Identification, Microprocessors, LED displays, 12V Battery, and Bluetooth module.

3.3.1 Wireless Communication Technology

One of the most important things is to be able to register the score accurately and quickly enough so there is no slow down on the normal speed of that game. From this one of the first questions was what wireless communications technology will be implemented so that that main goal can be achieved. Three of the technologies considered were BLE, RFID, and NFC. The first one stands for Bluetooth Low Energy as stated in the name it’s basically Bluetooth and only works when a device enters the range of the Bluetooth beacon. Once a device enters the beacons range all the Bluetooth does is send information to the device entering the range so with that we can already eliminate BLE since we need a wireless communications device that receives information and not just one at a time but multiple devices at one time and quickly.

Next, are RFID’s which stand for Radio Frequency Identification is a device which generally can detect objects and send and receive different information

depending on how it is programmed. To begin there are two kinds of Radio Frequency Identification's tags one is passive and the other is active. Passive Radio Frequency Identification are ones that don't require power to function when it passes an Radio Frequency Identification exciter which triggers the tag and information is either sent or received depending on the program and what the task at hand requires. These passive Radio Frequency Identification tags are great because they very small don't require a battery and can be placed on almost anything. Next, are active Radio Frequency Identification tags which are larger than passive tags and this is due to the fact that they do need a power source the extra bulk pays off in a longer range which may be more effect than passive tags in certain scenarios. Another pro for the Radio Frequency Identification is in their ability to read multiple tags at one time which would be greatly needed for this project.

Lastly, NFC and that stands for Near Field Communication this can mostly be seen on phones and ID tags, for example it is the technology that makes Apple pay, google wallets and others like it. This would also not work for the "Smart Cornhole" project because it wouldn't be able to detect multiple devices at the same time. Sometimes NFC and RFID are interchanged since they are very similar technologies especially at short range they are basically the same but Radio Frequency Identification is better in the sense that its range can be greatly increased. After reviewing these three technologies and some others it was decided that Radio Frequency Identification would be the best option for its ability to detect various signals at once and be able to tell the difference between each signal, so it would be able to detect the different teams bean bags. Now even further research on Radio Frequency Identification technology was needed to find out every small detail this is all in the section below.

3.3.1.1 Radio Frequency Identification

Once it was decided that Radio Frequency Identification technology was going to be implemented it was time to choose which Radio Frequency Identifier would best suit the needs of the project. Several Radio Frequency Identifiers were considered for the task at hand below is the original list of Radio Frequency Identifier's considered from many different models and companies. A lot of different options were observed as to make sure to get the best possible option for the smart cornhole project. Going more in depth into Radio Frequency Identifier's there even more differences then just Active and Passive tags. There are also differences in Frequency's as not all Radio Frequency Identifier's are created equal. There's three major categories for Radio Frequency identifiers which are LF, HF, and UHF which stands for Low Frequency, High Frequency, and Ultrahigh Frequency respectively. The main difference between each is the read range is extended the higher the frequency but each services its purpose.

Low Frequency RFID's usually operate at a range of 125 to 135 kHz which in range translates to about direct contact with the reader or about 1 to 2 inches from the reader depending on model and antenna. Used effectively the LF RFID would prove an effective way to design the Smart cornhole but all options must be considered.

High Frequency RFID's usually operate at a range of 3 to 30 MHz generally most use 13.56MHz. these of course extend the range slightly depending on all the changing variables of antennas used if any and model used the range could be from 5 inches to 5 feet. Another advantage this has over the LF other than longer range is also it's capable of high speed reading of tags which would be greatly useful.

Ultra High Frequency RFID's usually operate at a range of 902 to 928 MHz. This being the highest range from an RFID device of course yields the greatest range being capable of 3 feet up to 12 feet in some cases. While it yields the greatest range it also has the greatest chance of interference from basically anything in its field of range which is why while it could be the most beneficial it could end up hurting the project instead.

Lastly a big difference between each is not retail one would expect the UHF is more expensive than the other two options but thanks to advancements in technology now a days it is possible to use UHF for this project a couple years ago it would have cost an arm and a leg. Now that these three categories have been covered and also the difference between passive and active tags. The next step was to find out which was the best possible option for this project to be achieved and surpass expectations.

3.3.1.2 ID Innovations Readers

ID Innovation makes multiple RFID reader models this was first considered for its low cost and ease of use. ID innovation makes multiples devices but three in particular were looked at. These three were the RFID Reader ID-3LA, 12LA, 20LA. All three of these models are based on a Low Frequency scale and such have a short range.

The RFID Reader ID-3La or 3LA for short is innovations most basic model per se, which is why it almost got cut immediately after finding better options the main problem with this model is that an external antenna would be needed to even function. It would save more money if the antenna was already there internally which is what the other models provide. This model cost 29.95 dollars not too bad for what is being offered but again no antenna.

The 12LA model comes with an internal antenna and all for only five dollars more than the 3LA. It has a read range of about 120mm which was decided would not work for the cornhole. Thus, 20LA was looked into and with ten dollars more than the base price would get a read range of about 180mm. It only extended the range 60mm for five more dollars which wasn't well received within the group so the researched continued for better options.

3.3.1.3 RT400 UHF RFID Module

The first on the list to be a Ultra High Frequency RFID the RT400 can have a range of up to 10 meters depending on tags and antenna being used. For two hundred seventy-nine dollars, this module comes with its own antenna but sadly the range of this RFID reader is not given with said antenna. This would cause a great risk if one was to invest in this product and the results aren't as effective as one would hope them to be.

3.3.1.4 SkyeReader SuperNova

SkyeTek's RFID reader is small, lightweight and works on a UHF. What is special of this RFID is that it can be one hundred percent be powered by its USB port, it is also compatible with EPC class 1 Gen 2 tags. The very negative aspect of this model is that it comes in at 499 dollars which would be more expensive than double the cost of both the RT400 and SparkFun M6E mentioned below.

3.3.1.5 SparkFun Simultaneous RFID Reader – M6E Nano

This Ultra High Frequency Reader is compatible with Arduino MCU's which is a board being considered for this project. What is truly special about this one is its ability to read up to 150 tags per second of course the smart cornhole would never reach that limit but its great comfort to know that this board is up to the task. This RFID cost \$199.95 before taxes it's a lot of money but it would guarantee multiple reads at one time and hopefully no other purchase of say another antenna would be needed. The M6E Nano comes with an on-board antenna giving it a range of about one to two feet which would be all the range needed to cover the cornhole board this range can of course be increased with an antenna which the board provides a spot for an external antennas to be placed.

3.3.1.6 Comparing Radio Frequency Identifications

Above six different Radio Frequency Identifiers were discussed in this section the latter three will be compared as they are the only three that can possibly have the chance to successfully execute the Smart Cornhole. The three RFID's will be compared by the values stated by their respective manufacturers. These categories are Cost, Read Distance, and Power Consumption. Based on these different categories and what works best for the Smart Cornhole project the best RFID will be chosen.

3.3.1.7 Radio Frequency Identification Cost

The Radio Frequency identifier is the most expensive part of the Smart Cornhole. That being said is why the cost of the models is very important because the very purpose of the Smart Cornhole is for the use and joy of the average person. For the average consumer price is very important and to keep prices low one must use the cheapest product that can still get the job done. Sadly, even with today's advancements in technology RFIDS are still on the more expensive side as seen in Table 1.

From the table 1 it is clearly seen that the SparkFun M6E Nano offers the lowest price while nothing positive can be said about the SkyeReader SuperNova since that device is clearly the most expensive more than double that of the SparkFun. Lastly the RT400 is the second most expensive at \$279 placing it slightly below the SparkFun M6E Nano currently. Thus, the SparkFun M6E Nano wins the cost category.

3.3.1.8 RFID Read Distance

The read distance is very important in an RFID and especially for the Smart Cornhole project. Of course the read distance greatly differs if one would add an antenna to any of these RFID's but for this comparison the internal antennas each RFID comes with are being used which are given by their respective datasheets. The read of all these devices can reach great distances but for this project only about a 1.22 meter range is needed this would also help reduce the chance of interference from other items that maybe be in the RFID's range. The RT400 and the SkyeReader SuperNova are tied for maximum capable range while the SparkFun M6E has the smallest range but longer than the 1.22 needed for this project so all are still good options in this category.

3.3.1.9 RFID Power Consumption

In every device, project, anything really power consumption is really important it affects life time of products, or how long a product can be used before it needs to be recharged again. Since Cornhole is a game that can last anywhere from 30 minutes up to hours depending on the people playing the game power consumption plays a very important role on how this design can and should be implemented.

From the table below it is clearly seen that the SkyeReader uses the least amount of power while being idle which would make it last longer while the board is just waiting for people to play the game when can happen. The SkyeReader also uses a Voltage supply of 5 volts from a Universal Serial Bus or better known as USB connection. The operating power comes in at a close second ahead of the SparkFun.

The SparkFun doesn't win in any of the important categories only having the ability to need less voltage to operate. At 3.2 watts while operating it uses the most power out of the other three to read and comes in second while being idle and waiting for a tag to read. The only thing the SparkFun has in it's in voltage required to operate which is possible at 3.7 volts. While the RT400 on the other hand has the lowest operating power which is really good for when the game is actually being played it should last longer than the other RFID's before the battery needs to be replaced or recharged.

Table 3: RFID Comparison

Comparing	Read Distance	Cost	Power Consumption
Radio Frequency Identification (RFID)	Meters	Unit Price	Idle Power Consumption (W)
SparkFun M6E Nano	.304 - .609 (up to 4.9 with correct antenna)	\$199.95	0.015
RT400	.1 -10 (depending on antenna & RF)	\$279.00	0.72
SkyeReader SuperNova	6 (passive) 10 (active)	\$499	0.00005

Table 3 above is a combination of all the different aspects of the radio frequency identification device. The values shown in the table are power consumption of

each radio frequency identifier in watts this is calculated by multiplying the operating voltage times the current draw of the system, the read distance in meters and the cost of each radio frequency identifier which is then compared to the cost of the cheapest radio frequency identifier by percentage to better see the difference in cost.

3.3.1.10 RFID Final Decision

After comparing the three different Radio Frequency Identifiers the SkyeReader SuperNova is almost immediately removed from consideration as it's cost far exceeds the others and it doesn't matter how good it maybe it is not feasible with the group's current budget. While it did have the lowest power consumption that would not help the final goal for this project to one day sell it to consumers if this RFID would be chosen the minimum the Smart Cornhole would sell for just to be even would be 600 dollars which not many if any at all would chose to buy a Cornhole for that price.

That leaves the RT400 and the SparkFun M6E Nano, the RT400 is a little more expensive than the SparkFun but it also has a lower power consumption and a longer reading range. That being said the group decided that it was not worth paying an extra eighty dollars over the SparkFun would be worth it. Since most of the reading range would be wasted as not needed since the board is only about 1.33 meters, so only a maximum of 1.5 meter reading range is needed and the power consumption savings is miniscule.

The RFID that was chosen was the SparkFun M6E Nano it was the cheapest of the three models which was a big pro for this model it also had the desired reading range without having to waste any range that might become a hassle with interference from other things. A very extremely important fact about the SparkFun is its ability to read up to 150 tags per second which is really impressive and required for the Smart Cornhole. The only negative is that with a 3.2 watt power consumption during operation it might reduce the play time of the game before another battery is needed but it should not be that much of a draw should be effective for at least two consecutive games. For these reasons the group decided on this RFID reader.

3.3.2 Microprocessor Units (MCU)

One of if not the most important aspect of this project is the microprocessor which can also be called the brain of the whole operation. The microprocessor is a chip usually on a printed circuit board which is programmed to handle the task at hand whatever that may be. As the brain of the whole project this is the object that must be chosen with great care it must be able to handle any task needed to successfully create a smart cornhole. There are many different microprocessors

by many different manufacturers and many more models by each manufacturer with all this it can be easy to get lost in all the details, so great care was taken in choosing a handful of microprocessors. Each group member had the task of researching for the best microprocessors they could find and so the following list was born.

3.3.2.1 Texas Instruments

Texas Instruments is a well-known name at UCF so it is no surprise that it was considered for this project. There are so many microprocessors in the Texas Instrument catalog it was difficult to narrow them down. All four members having experience with Texas Instruments the group ended with for different version of the MSP430 family which include the MSP430FG6425, MSP430FG6426, MSP430FR75976, and MSP430FR5994.

3.3.2.2 MSP430FG6425

The MSP430FG6425 is a very capable microcontroller with a frequency of up to 20 MHz and a very low active power as that is what the MSP430 line is known for, this model runs at two hundred and fifty $\mu\text{A}/\text{MHz}$. This MCU comes with ten kilobytes of Ram and sixty-four kilobytes of flash memory. One of the real nice aspects of this MCU is that it has an available 73 GPIO pins which makes for many possible connections which benefit out project. That along with the very low supply voltage of 1.8 to 3.6 Volts.

3.3.2.3 MSP430FG6426

Sharing many things with the previous model stated the MSP430FG6426 is a better version of the MSP430FG6425. This model has double the flash memory at 128 Kbytes that makes for a faster MCU that will make it not have a tough workload. Since the MSP430FG6425 is the better version and only cost about fifty cents more for double the memory. The above model is priced at \$9.53 while this model is \$10.05 this makes it easily a bargain and so with that the MSP430FG6425 was dropped from the list of possible MCU's.

3.3.2.4 MSP430FG5994

This MCU cost a cheap price of \$7.81 per unit very affordable. It is capable of a frequency of 16 Mhz and it does have a lower GPIO count than the previous two models this one has a maximum capacity of 68 pins which is less connections but to be honest 73 is a bit too much for this project. Continuing on with the family

of ultra-low power MCU's this chip consumes about 120 micro amps per one MHz. A huge pro of this model is that it only has 8 KB of RAM and it does have 256 KB of flash memory which is more than enough for any task it would be programmed, at least for this project.

3.3.2.5 MSP430FG5989

This model comes in at \$9.42 which is not too bad but compared to the model above it cost more for what seems to be less. The MSP430FG5989 seems to have less of everything this model has the least amount of GPIO pins than any other model at only 48 pins. That might not be too bad since the low pin count might actually work well for the Smart Cornhole but sadly this model also only has 2 Kilo Bytes (KB) of RAM which might not be enough it does still have 128 KB of flash memory but the RAM seems too low for peace of mind. That being said how this one is more expensive than the MSP430FG5994 is not entirely clear, only possible answer is that TI has several manufacturers that sell these models and their prices vary slightly depending on which manufacturer one buys it from but shown prices are the cheapest found for all models at the time this was researched.

3.3.2.6 ATMEGA 2560

The ATMEGA 2560 is a microprocessor chosen by the computer engineer in this project, based on the fact that these microprocessors can be seen on Arduino printed circuit boards and are easily programmable. After looking at many MCU's from Texas Instruments it was a nice break to look at MCU's from other companies the ATmega 2560 which is made by Atmel. This one was considered because it comes included when one buys the Arduino MEGA 2560 which is very well known software and very easy to learn and implement according to the computer engineer that has some prior knowledge with this model. Stating that this cost 45.95 dollars with the board it can also be bought without that board and that would be 12.70 dollars. The ATmega2560 comes 256 KBytes of flash memory and 8 KBytes of RAM this is really good for the Smart Cornhole. This MCU is also capable of up to 86 GPIO pins which is the highest number seen so far and as some say the more the merrier.

3.3.2.7 STM32L072RBT6

The STM32L072RBT6 is an MCU from a company called STMicroelectronics no one from the project group had heard of this company before but one of the electrical engineers has an internship with a company that uses these MCU's and said he might be able to get a couple for the Smart Cornhole project. As of the time this is being written this still hasn't been confirmed or denied. Even then the

group researched MCU's from this company and was happy to learn they are a well-known company and are known for making good MCU's.

Back to the main MCU at hand is the STM32L072RBT6 which is capable of operating at a 32 MHz frequency. This low-power microcontroller has the ability to function with a power supply of 1.65 to 3.6 V very low and very good, which leads to the current draw to be ninety-three micro amps per MHz during active mode. The flash memory capacity is 128 Kbytes with a RAM capacity of 20 Kbytes which puts it up there with the other MCU's it is competing with and it includes a memory protection unit to help not lose any programs. Lastly, this MCU has a capacity of up to 84 GPIO pins.

3.3.3 Comparing Microprocessors

Below will be a many different tables comparing different aspects of all the before mentioned microprocessor units. The comparisons will be based on what is stated by the manufacture and judged on what will be best for the Smart cornhole project. These comparisons are from power consumption, memory size, clock frequency, general-purpose input/output pins, and cost. By doing this it will help eliminate the microprocessor selection to hopefully the one that is truly needed to complete the project.

3.3.3.1 MCU Power Consumption

A significant difference between the Radio Frequency Identification and a microprocessor besides the obvious of course is that it also consumes way less power which should help increase life time of the Smart Cornhole. The power consumption is calculated from using the operating voltage times the DC current which gives power consumption in watts but since current is left at milliamps then power is really in milliwatts.

From the Table 4 it is seen that the STM32L072RBT6 is the most power efficient MCU of the rest by a margin of 41% to its closest competitor which just makes the others not even close. The other three microcontrollers all use the same operating voltage of 1.80 volts but with a different DC current which affects the power consumption this resulted in the ATmega 2560 using the most power at 0.900 milliwatts followed by the MSP430FG6426 at 0.450 milliwatts and lastly the MSP430FG5994 with a power consumption of 0.216 milliwatts. Thus, with a wide margin the STM wins the power consumption category.

Table 4: RFID Power Consumption Comparison

Power Consumption Comparison			
Microcontroller (MCU)	Operating Voltage (V)	DC Current (mA)	Power Consumption (mW)
MSP430FG5994	1.80	0.120	0.216
MSP430FG6426	1.80	0.250	0.450
ATmega2560	1.80	0.500	0.900
STM32L072RBT6	1.65	0.093	0.153

3.3.3.2 MCU Memory Size

Memory plays a crucial part in a microcontroller it controls how big and detailed a code can be the more memory space the more wiggle room there is to make a great code instead of being confined to a small amount of memory reducing the code. This is done with two main types of memory the first being Flash memory this is non-volatile memory which means it is not erased when the MCU is turned off and on it is where the code is stored in the microcontroller, RAM which is volatile and slower than flash memory this is used to store the results and other temporary data the microcontroller might be receiving during use. Both Flash and RAM are very important Flash to have enough space for code and RAM to have enough space for all the calculations and results so more memory is better. Below the table shows the comparisons of each microcontrollers Flash and Ram memory capacities.

Both the MSP430FG5994 and the Atmega 2560 are identical in flash and RAM capacity it's a draw for them but compared to the other two microcontrollers they have double the flash memory which is great for coding but they lack in RAM capacity as they only have 8 KB thus being the least. The clear winner in the RAM category is the STM32L072RBT6 with 20 KB is more than double the size of the RAM in the ATmega. For the memory category, there is no clear winner the group is leaning towards more flash memory for code since it is believed there won't be too many calculations and values to record while the game is being played. The deciding factor will have to include the other categories.

3.3.3.3 MCU Clock Frequency

The main object for the Smart Cornhole is for it to be able to automatically detect and display the score accurately and fast. To accomplish the speed aspect a fast clock frequency is needed this is the rate that allows the microcontroller to execute instructions. The quicker the CPU the faster the score is read and displayed so that there would be no real-world lag seen by the consumers playing their game of cornhole.

The two slowest microcontrollers are the MSP430FG5994 and the ATmega 2560 with a frequency of sixteen megahertz which isn't bad by any means but is the lowest capacity from the microcontrollers considered. While the MSP430FG6426 has a frequency of twenty megahertz making it a little faster than the other two but the winner of this category is by far is the STM32L072RBT6 with a thirty-two megahertz capacity making it double of the lowest two microcontrollers, thus giving the win of the clock frequency category to the STM32L072RBT6 microprocessor.

3.3.3.4 MCU General Purpose Input/Output

The general-purpose input/output pins or GPIO for short are pins that allow for connections with other devices and those pins can send and receive data as well as power. Depending on how many connections one needs the more connections the better or if only a couple are needed with more capacity that too can be done.

There is no real winner for the GPIO category as they all have over sixty pins which is more than enough for the Smart Cornhole but the ATmega does have the most pins with eighty-six and the MSP430FG5994 the least with only sixty-eight pins. The quantity of the pins is considered the more the better for now as the number of pins needed is still unknown.

Below is a Table 5 is a combined table with all the values of the various microcontrollers in one simple to understand table. The table includes the values for clock frequency first, followed by a general purpose input and output pins comparison. The next thing shown on the table is the cost for each microcontroller as well as their percentage if cost compared to the cheapest microcontroller chosen. Lastly, at the bottom of the table is the memory capacity of each microcontroller a very important part of a microcontroller as this allows for better codes.

Table 5: MCU Comparison Table

Comparing	Frequency	GPIO	Memory		Cost
Microcontroller	Clock Frequency (MHz)	# of GPIO Pins	Flash Memory	RAM	Unit Price
MSP430FG5994	16	68	256 KB	8 KB	\$7.81
MSP430FG6426	20	73	128 KB	10 KB	\$8.16
ATmega 2560	16	86	256 KB	8 KB	\$12.70
STM32L072RBT 6	32	84	128 KB	20 KB	\$4.76

3.3.3.5 MCU Cost

A very important factor is cost as stated before in the radio frequency identification section an objective of the group is too keep cost low for the consumer. The less spent on parts and materials the cheaper the Smart Cornhole can be sold for since no one is likely to buy for a high price. Luckily microcontrollers are very cheap and not as big of an issue like the radio frequency identifier.

The STM32L072RBT6 is the cheapest by far with a price tag of 4.76 dollars everything else is almost double or triple the price. The ATmega 2560 being the most expensive at 12.70 dollars very surprising wasn't expected to be above the ten-dollar mark. That leave the Texas Instrument microcontrollers in between those two at about eight dollars each. Clearly it would be a bargain to get the STM as two or three could be bought with the same amount of money it would cost to buy from its competitors.

3.3.3.6 Microcontroller Final Decision

After comparing the four microcontrollers it seemed clear that there was no need for the two different MSP430's as they seemed virtually the same and the FG6426 was outclassed by the FG5994 in several categories such as in cost, memory, and power consumption, while the FG6426 did win in GPIO pins and clock

frequency they aren't viewed as highly as the other three categories and for those reasons the FG6426 was dropped leaving three for consideration.

The final three all from separate companies and different specifications after looking at the comparisons one might say that the STM32L072RBT6 is the winner as it dominates in most categories. Which is odd as it is also the cheapest which usually is not the trend, but as mentioned when this model was introduced that it was under consideration if one of the electrical engineers could receive them from the company he is interning. As of the time this is being written there is still no word and the group continued with another microcontroller.

Then there was two while many in the group considered the MSP430FG5994 to be a better choice over the ATmega 2560 in both cost and power consumption as all other categories these two were the same. In the real world it is not what you know but who you know and that is exactly what occurred here everyone was ready to decide on the FG5994 but then the computer engineer deeply recommended the Atmega 2560 for he had previous experience with this microcontroller and that it can come implemented on an Arduino board which he has experience on. After much review from the rest of the group it was considered that while cost and power consumption are greater for the ATmega it wasn't a big enough change to really affect the Smart hole budget or power constraints since all the other categories were identical. Furthermore since the computer engineer was in charge of all the programming it would be a better to choice a microcontroller he was comfortable with and with that it was decided that the ATmega 2560 would be the microcontroller to implement the Smart Cornhole.

3.3.4 Battery Packs

Every system in the world needs some sort of power source it is one of the most important discussions around the world how should energy should be collected and used for Smart Cornhole project power is to be received by a small, lightweight, portable battery pack. It will be used to power all the elements on the board such as the MCU, RFID, XBee, Bluetooth module, LCD display and the speakers.

Many different types of battery packs were considered for many different reasons these ranged from power tools, RC, and portable USB battery chargers. The power tool battery packs were considered for their simple slide in and out charge feature. If that feature could be implemented on the Smart Cornhole board it would make it more convenient for the consumer to operate the board and keep it constantly charged with just two batteries while one is on the board the other is charging in theory this method would insure that the Smart Cornhole is always ready for a game.

Battery packs usually used to recharge phones and other devices were considered for they small and lightweight and simple design which would help implement the battery on the board with not much added weight or bulk. Known for charging and discharging efficiently. Lastly, RC batteries or batteries usually found in RC cars, dolls, and other small products. Have a bulkier design to them but are essentially the same as the electronic devices pack just not visually good-looking since they are usually hidden in the device they power so in that aspect it still would serve the Smart Cornhole.

3.3.4.1 Battery Comparisons

Five different batteries were chosen from various types of battery's two of them were power drill style batteries, another two were batteries usually found in RC's or dolls and lastly the last one was a charger usually used to charge phones and other devices. These five different batteries were chosen and researched to make sure the best possible option was chosen to optimize the project and get the desired result of play time. The team believes a minimum of three hours the board should be able to run before it need to be either recharged. This would allow a good amount of time to play multiple games without the consumer worrying about the battery dying.

One of the chosen batteries is the DeWalt 12v 1.5Ah DCB120 Li-ion battery this was the first one researched DeWalt is a very well-known name in the power drill industry thus making it more likely to work to specification than other lesser known brands. This battery is made from a lithium-ion chemistry which is good less toxic than a lead-acid battery. This battery also has the lowest capacity at 1.5 amp-hours meaning it would be able to last long before it needs to be recharged. Lastly this battery has a price tag of 26.99 dollars making it on the more expensive side especially if the price of the charger of the battery is added since the charger is not included in the purchase of the battery which can be another twenty dollars making it easily over a fifty dollar purchase.

The second battery is another drill type battery made by Black and Decker another well-known company this one is a 12v battery with a 2 amp-hour capacity making it half an amp-hour more than the DeWalt. This one is made by a different chemistry it is a Nickel-CD battery not as common as lithium-ion chemistry but still very effective as this battery chemistry can take a bigger beating and has a longer life span if treated properly. That is why the cost is probably a little higher than the previous one mentioned, this battery comes at a cost of thirty-nine dollars and again this is just the cost of a single battery not including a the battery charger or a second battery.

The third battery is a different type than the other two in design of course because the function is always the same this is the Tenenergy based on the design it seems

to be implemented on Radio Controlled (RC) airplanes this like stated before doesn't change the function of the battery pack but it makes it a little more spread out and comes with the wires ready to be connected unlike the power drill battery packs these wouldn't be implemented to slide in and out but would either be soldered directly to the board or converted to a DC connector. The battery pack has a capacity of 2 amp-hours just like the Black and Decker and just like the Black and Decker it is a Nickel type battery this chemistry is a little different and is mostly seen in small batteries such as AA and AAA batteries made by companies such as Duracell, and Energizer. A very durable battery chemistry but a big con is that its known to self-discharge over time. The cost for this battery is about twenty dollars this battery pack also doesn't include a charger but it is cheaper than the power drill options.

While researching for batteries a good optioned appeared that was unbranded it was just a battery from china being advertised on a website for very cheap of course this made it very tempting so it was included for consideration. Nothing is known about the manufacturer or if it can be trusted but from the specifications given it has a 3 amp-hour capacity with a lithium-ion chemistry again might not be reliable but just have to go based of the information given. This battery is the cheapest at \$8.51 which is more than half the price of any of the other batteries mentioned. Surprisingly it is the cheapest but it does come with a charger to charge the battery pack unlike the three previously mentioned batteries but it's not a wall charger so not convenient for the consumer.

The last battery pack is made by a company named Hitlights not very big but is based here in the states their lithium-ion battery is rated to have a capacity of 3.5 amp-hours more than any of the other batteries. This battery pack cost \$24.99 but it includes the battery, charger and an extra cable for connecting the battery to a DC powered device. Below is Table 6 which has a summary of all the batteries in three categories which are capacity, chemistry, and cost since these three values are the most important values for the group in choosing the battery the will be implemented in the project.

Table 6: Battery Comparisons

Battery	Capacity (Ah)	Chemistry	Cost
DeWalt	1.5	Li-ion	\$26.99
Black & Decker	2	NiCD	\$39.00
Tenergy	2	NiMH	\$19.99
"Unbranded"	3	Li-ion	\$8.51
Hitlights	3.5	Li-ion	\$24.99

3.3.4.2 Battery Pack Decision

After getting all the data from the various batteries as seen in the table it can be seen that different batteries hold different advantages in different categories such as the Hitlights having the most capacity out of the five. While the Unbranded battery is the cheapest battery. In the chemistry category, there is no real winner because for what the Smart Cornhole is being used for chemistry isn't that important.

The first batteries to be eliminated were both of the power drill style batteries for three reasons. One the cost of the batteries is over our budget and couldn't be afforded especially since two batteries are needed to be purchased for the battery. That along that it doesn't come with a charger the price only continues to increase for both of these batteries. The second reason these are being dropped is because their implementation onto the board might not be possible. Originally the power drill type batteries were chosen for that simple slide in and out feature but as the group continued to ponder how that would be implemented and that it had to be converted so that it could power the printed circuit board (PCB). Converted as in that the PCB doesn't have pins like a drill does for the battery to slide into cables would have to be added to connect the two that would kill the whole concept of sliding in and out in the first place. Lastly, it was decided that neither 1.5 or 2 amp-hours was not enough capacity for the Smart Cornhole to run for at least three hours guaranteed and for those three reasons the power drill batteries were dropped.

The Tenergy an RC airplane style battery with twenty-dollar price tag and same capacitance as the power drill batteries is basically the same just differs in shape. That is why it was dropped from consideration for most of the same reasons the power drill batteries were dropped from consideration which was mainly no charger, cost, and not enough capacity at only two amp-hours. It was priced cheaper than the power drill batteries but there were better options in the Hitlights and in the unbranded battery from china. Thus, the Tenergy was dropped from consideration also if that wasn't enough the shape of the battery wasn't well suited for the Smart Cornhole.

The final two batteries the unbranded and the one made by Hitlights were both good contenders. Both have the capacity that the group was looking for, they came with the chargers so no additional cost was added which also meant these two batteries were the cheapest of the five. The hitlights has the biggest capacity with 3.5 amp-hours only half an amp-hour more than the unbranded battery which meant that the unbranded battery would be the better choice because it was more than half the cost of the hitlights battery for about the same capacity and same battery chemistry. In theory, of course but after much discussion it was decided that for two reasons it would better to go with the Hitlights battery. The

first being that it was an unbranded battery from china and chances of it not working were possible and with time constraints that was not an option. The second reason goes back to the location of the battery it is in china and with the shipping it could take up to a whole month before it arrived which would be a big problem. For these reasons, it was decided that Hitlights was the way to go with 1-day shipping, the most capacity and most importantly it came with the charger for the pack unlike almost all the other options.

3.3.5 Bluetooth Modules

Since the start of the project the group knew that Bluetooth speakers would be implemented onto the project for the customers. The only question was how would it be implemented would we just buy speakers from a store and connect it to our project or would we take an extra step in personalization of this project and make it one hundred percent ours. This led for the group to decide that we would design and create our own Bluetooth speaker. This started the research into Bluetooth technology and what would be needed to execute this part of the project and found we need audio Bluetooth modules since there is various kinds of Bluetooth technologies for various tasks.

3.3.5.1 Bluetooth Module Comparisons

The Bluetooth module is very important for the entertainment aspect of the project of course the customers buy the Smart Cornhole mainly for the board the game itself but this would push the entertainment aspect too the next level so that the customer can have more fun by setting the mood with his or her music for themselves and/or guest. To choose the best option different models had to be looked at and compared to make sure it would operate at a caliber satisfactory to the project specifications.

Four Bluetooth modules were considered the KC-6012, Bluegiga WT32i, BC-127, and the RN-52. It may seem a little confusing just looking at their names with letter and numbers but let's break them down. The KC-6012 bluetooth module made by KC wirefree has a broad range of twenty-five meters which it can get information from any other Bluetooth device in this case the phones or music devices of the customer. That much range isn't needed as the players will always be one to two feet from the board which is also were the Bluetooth module will be located. The most important thing in Bluetooth is the data rate as it needs a big enough data rate to be able to reproduce the signal of music which is known to be about 706 Kbps. The KC-6012 is over this value but just barely which doesn't convince the team very well.

The second Bluetooth is made by a company named Bluegiga is the WT32i it has an even broader range of thirty meters and only for seventeen more pennies. The

data rate for the WT32i is 2.1 megabytes per second way better than the KC-6012 guaranteeing that the sound quality should be good. The only thing that could not be researched about this model was its current draw so the power consumption couldn't be calculated which is very odd since that is basic information that should be in all datasheets.

The third Bluetooth module is the BC-127 the BC stands for Blue Creation which is the company that makes this module. This module is the most expensive one but only by two dollars. The good thing about all these Bluetooth modules is that they all cost relatively the same. This leads to decisions not being based on price but what truly is better for the Smart Cornhole project. The BC-127 has a data rate of 3 megabytes per second tied for fastest data rate with the RN-52. Making it the one of the two best sound quality Bluetooth modules for consideration. It also has a range of up to thirty meters. Lastly, the BC-127 is the most power efficient module out of the four with a power consumption of forty-nine milliwatts. That is half the power consumption of the next best thing which is good since the battery should really focus on powering the speakers.

The last module is the RN-52 again the letters in the name stand for the company which in this case is Roving Network. This module is tied with the BC-127 for fastest data rate which is good at three megabytes per second. The only con about this module is that it has the shortest range at only ten meters but again this isn't as important since the players are in a one meter range of the cornhole board. At the cost of only twenty-five dollars it is tied for cheapest with the KC-6012. This is the second most power efficient module after the BC-127. This makes the RN-52 a very good option as it is also widely known and used since it is a product displayed and offered in the popular site Sparkfun.

Table 7: Bluetooth Module comparisons

Bluetooth	Range (m)	Data Rate (Mbps)	Cost	Power Consumption (W)
KC-6012	25	0.768	\$25.00	0.118
Bluegiga WT32i	30	2.1	\$25.17	N/A
BC-127	20 - 30	3	\$26.95	0.049
RN-52	10	3	\$25.00	0.099

Above is Table 7 which has all the values for all the Bluetooth modules in a short organized table making it easier to see and compare all the values with the four modules. The table includes values such as Range, Data Rate, Cost and Power Consumption. These four values are the main points of which the Bluetooth

module was chosen as all the modules provide the same technologies these are the main differences.

3.3.5.2 Bluetooth Module Decision

After looking at the results of our research on Table 5 there is no clear choice but by process of elimination one was chosen. The first two almost immediately dropped from consideration were the KC-6012 and the Bluegiga WT32i for different reasons. The KC-6012 was dropped because of its low data rate for the same price the RN-52 has more than triple the data rate. For this reason the KC-6012 was dropped.

The Bluegiga WT32i was dropped from consideration for two reasons again the data rate was not the fastest and it was a little bit more expensive. Secondly there was no current draw value which meant no power consumption could be calculated which isn't a problem per se but it is not a good reflection of the product if it lacks such basic information that is found in almost every product. That is why the Bluegiga WT32i was dropped.

This left only two options left the BC-127 and the RN-52 they both have identical data rates, but differ greatly in range since the RN-52 can only work up to 10 meters this is not necessarily bad since only one meter is needed and having a range of up to thirty meters makes it more susceptible to interference. At a power supply of 3.3 volts the BC-127 is way more power efficient than the RN-52 which is great for battery life of the system so the customer can enjoy it for longer before it needs to be recharged. Lastly, the cost is basically the same except that the RN-52 is two dollars cheaper.

After considering all these values it was finally decided that the group would use the RN-52 the group member researching this part really held high praise for it that he would be able to program it and that it would run effectively. This product was already on the SparkFun site which was the site that other items were being purchased at which made the buying and shipping easier and more likely that everything would arrive at the same time.

3.3.6 LED Display

A Light Emitting Diode (LED) display is a crucial part of the project since it is the physical representation of all the work done behind the scenes. The light emitting diode will display the scores for both teams. At first a Liquid Crystal Display (LCD) was considered since they consume less power than an LED but LCD's are not as bright. This would lead to problems of the display not being visible and the players wouldn't be able to see the score when the game is being played outside in a bright and sunny day. Lastly, the LCD's usually display actual words in a very

small screen which just wouldn't do for the Smart Cornhole. A LED display was the solution having chosen a light emitting diode type display it was time to find the actual display as in there are many several types of LED displays for example a television is one kind but of course that will not be used in this project it would be redundant.

For the Smart Cornhole project seven-segment display light emitting diode would be needed these come in many sizes from less than an inch to a couple of inches. A set of four will be needed to for each team since the maximum score is twenty-one only two digits need to be displayed. The display should be easily readable from a distance of at least ten meters since that is the distance between the two boards. The LCD displays will be on each board so that every player can visibly see the score.

3.3.6.1 Comparing LED's

Three light emitting diode models were chosen and researched. The two of the three displays are from the same company named China Young Sun Led Technology. The last one is made by a company named Alzatec. All three are made in China and are multi-colored displays which is necessary as each teams score will light up a distinct color that way it is easier to differentiate each team score and no confusion can occur.

The first light emitting diode display is the one manufactured by Alzatec it is a 2.3 inch tall display which should have good visibility from a distance especially since it has a luminous intensity rating of 190 mcd which is bright enough to be seen outside in the sunlight. At a price of eight dollars it is the middle option in all categories its neither the best nor the worst.

The second model is the YSD-1100AR7B-15 this a big one at six inches it can be seen from a hundred feet away which is way more than is required and this is shown in both power consumption and cost. The bigger the light emitting diode the more power it will draw. This one consumes 240 milliwatts which is more than double the Alzatec which is in second place at 84 milliwatts. The price is almost the same story a little bit less than double it comes in at \$14.95 and if that is multiplied by four since that is the total number needed the actual cost will be \$59.80 before taxes.

The YSD-160AR4B-8 is the final light emitting diode display on the list. This display is the smallest at one inch it might not be big enough to be seen ten meters away or 33 feet in SI units. This being the smallest it is by far the cheapest, most power efficient display out of the three. With a price tag of ninety-five cents all four could be bought for half the price of one Alzatec display. The luminous intensity is rated at 75 mcd which might be too low to be seen clearly outside in

a sunny day which is the ideal weather to test it in. The size and low luminous intensity leads this to be the most power efficient LED display at only forty milliwatts which again is half the power consumption of the Alzatex which has a power consumption of 84 milliwatts.

Table 8 below shows all the values gathered from the research in simple to understand table. The values on the table include size of the LED, luminous intensity, power consumption, and cost. The cost displayed is the price for just one unit to find the cost of the complete set before taxes the price shown must be multiplied by four.

Table 8: LED comparisons

LED	Size (inches)	Luminous Intensity	Cost	Power Consumption (mW)
Alzatex	2.3	190 mcd	\$8.00	84
YSD-1100AR7B-15	6	250 mcd	\$14.95	240
YSD-160AR4B-8	1	75 mcd	\$0.95	40

3.3.6.2 LED Final Decision

After examining all the information in the table shown above the group had to decide which LED it would implement on the Smart Cornhole the Alzatex was chosen because it's the best of both worlds it is big enough to be seen from a distance in a sunny day. It also doesn't consume as much power as the six inch model which is too much that size is too big and not necessary let alone the price would rival that of some major components for something that has no real technology. For these reasons the 2.3 inch Alzatex was chosen to be part of the Smart Cornhole project.

3.3.7 Minor Component Parts

This section goes into over other parts used to implement the Smart Cornhole but not in such detail as the previous sections as this is on minor components and parts that aren't really microcontroller based or the brains of anything just parts needed to complete the project such as Xbee boards to communicate wireless for each microcontrollers on the different boards, LED strip lights for a better physical appearance and parts such as those.

3.3.7.1 LED Light Strips

Light emitting diodes will be used to make the board more physically appealing with radiant light and a choice of multiple distinct colors. LED strip lights have become a very common site seen almost everywhere on anything this is good as they can also be bought from many different sources with many different varieties to accommodate different needs and wants. Even though it is seen everywhere there are some aspects most people don't know about LED strip lights until they are actually doing research to purchase some lights and these include: Lumen, Correlated Color Temperature (CCT), Color Rendering Index (CRI), and number of chips per strip. All these things are important things to check before making a purchase on any LED strip lights to have the expected results when the LED's are finally connected.

First off is lumens which is the unit in which the brightness of light is measured. Depending on the needs of the customer of low light or a bright light the limit of lumens for each LED strip lights should be considered, but what is a lumen how bright is one lumen. Well lumen is based on candela times steradians to further explain this one candela is the brightness of one candle as candela means candle in Latin. Steradians is just the unit of 3-D circle with the 4π making a complete circle since light shines in all directions but if the light was covered to only shine in one direction the steradians could be 2π but still one candela of physical light. This is the overview of lumen and how its measured.

Correlated Color Temperature (CCT) is really only related to the color white and its intensity. For example, there is white light that has a yellow glow to it making seem like a warm white then there is white that is really white and bright that it even seems a little blueish called a cool white. These whites are measured in kelvin usually the warm yellow white lights are in the range of 2700K - 3500k with a neutral white around 3500k - 6000k and anything higher than 6000K is considered cool white the brightest of the bright.

The Color Rendering Index (CRI) is the final major aspect of what to look for in a LED strip lights before purchase. Color Rendering Index refers to how the color of objects actually look's in comparison to natural sunlight. The index runs from 0 to 100 with 100 symbolizing that the colors look the same as they would under natural sunlight. This isn't really important for the Smart Cornhole since the group is not interest in displaying color in its natural state this would serve more for projects where accurate colors are needed to differentiate or enable certain services but not for a game board. For example, if we had decided to use a camera to detect the colors of the bean bags used in the Smart Cornhole then this would be a very important aspect to look into since we don't what the LED strip lights to change the color the camera might perceive the bag as and therefore causing error in the scoring of the game.

There are other things the group considered when choosing an LED strip for the Smart Cornhole. Mainly LED chip size and number of chips per strip. Not all LED strips are created equal and this a very important factor in that a strip with six hundred LED's is going to be brighter than a strip that only has three hundred LED chips even if you consider that the three hundred strip could have a bigger, brighter chip quantity beats individual brightness when it comes to light in LED light strips. Going back to size there are different light emitting diode sizes such as the 3528, 5050, 2835, all these number stand for is the chip size in millimeters so the 3528 chip is 3.5 X 2.8 millimeters and so forth for the other chips. As one would assume the bigger the chip the brighter the light but also the higher consumption to light the LED's so it all is based on need and what is being used to power the LED light strips.

Lastly, RGB Color was desired for any LED strip lights chosen this feature allows for any color to be displayed on the light emitting diodes. RGB stands for the colors Red, Green, and Blue these three colors at different intensities are used to display thousands of colors. This is in most LED light strips but need to make sure since there are ones made just for white or a certain color.

3.3.7.2 MENZO LED Strip Lights

The Menzo Strip light is the LED strip lights chosen for the Smart Cornhole. It is a 3528 LED chip went with this size because it is more power efficient than the commonly used 5050 while also providing the light desired by the group. It also comes with six hundred chips per reel which is five meters. Powered by a 12-volt five-amp power supply. These were within budget and offered everything that the group desired and so the MENZO LED strip lights were chosen to be implemented the Smart Cornhole.

3.3.8 Xbee Shield

The Xbee shield is a device used to allow wireless connectivity with devices that don't have such capabilities such as a microcontroller. Which is the very reason it will be implemented on the project. To connect the two cornhole boards ideally to show the proper score and not a separate score for each board.

The Sparkfun Xbee shield is the one that will be found in the Smart Cornhole at a price of \$14.95 it's not too costly and it can be easily adapted to any Arduino style board. We will have our own printed circuit board but the pin layout will be similar enough so that the Sparkfun Xbee shield can also be easily adaptable to the Smart Cornhole.

3.3.9 Voltage Regulator and Amplifier

Most chips being used for the Smart Cornhole run on either 3.3 volts or 5 volts but the power supply outputs 12 volts. This is solved by adding a voltage regulator to lower the voltage to the required value for the chip at hand. The Voltage regulator chosen is the LM1084 which has several models such as an adjustable voltage regulator set by using resistors or there is also fixed regulators that come with an already predetermined voltage of 3.3 or 5 volts which is luckily the voltages we require. The LM1084 cost three dollars the ones being purchased are the fixed voltage regulators to avoid extra components and for a more precise voltage getting an adjustable voltage regulator would just add error because of the resistor values would never be exact since all resistors have some sort of tolerance. One of each the 3.3 and 5-volt regulator were purchased since one of each is needed in the project to run their respective chips.

Since the group decided to implement our own Bluetooth speakers an amplifier is needed to make a significant gain so that the speakers would actually get their required power. The amplifier for the job is the LM386 by Texas Instruments it is a low voltage audio power amplifier it comes with an internal gain of twenty but this can be increased up to two hundred by adding a resistor and capacitor with the values for the desired gain. At a price of only a dollar with a quarter that is very cheap and this is specially designed for amplifying audio since early on the group decided to use an op-amp given to students for their electronics two course but it didn't work as expected since we did achieve a gain there was also a lot of noise and using the LM386 which is specially created for this one task eliminates the noise while adding a gain.

3.3.10 Speakers

The Smart Cornhole requires speakers that will be attached to the Bluetooth module. The speakers had to be small enough to fit into the board but also strong enough to be heard above a certain sound level since we are expecting that the environment the Smart Cornhole will be around is noisy with a minimum of four people around and most likely other guest or spectators. All that being considered three inch, 0.3 watt, 16 ohm speakers were chosen they should be enough for the previously explained goals in mind.

3.4 Printed Circuit Board

The printed circuit boards (PCBs) are the most common way to assemble microelectronics as of now. The printed circuit board connects and maintains

components in their place. This provide the designers a professional way of implementing all the components together. The printed circuit board are made up of conduction pads, tracks, and other features made of copper, which are laminated with non conductive material. The printed circuit board can be design with many layers; most designs are at about eight layers. These layers are put together in a sandwich pattern, between the layers of copper, there's insulation material. Printed circuit board provide more durability and reliability to the design since it eliminates the possibility of shorts circuits or false connections.

3.4.1 PCB Design Software

A software to design the printed circuit board is needed after the schematic is done. These types of software are often referred as electronic design automation (EDA), which are necessary to develop the printed circuit board design. The software is first used to design the schematic of the prototype, this is based on components that had already been designed, which can be simply added to your design component's library. The circuit diagrams are then turned into printed circuit board design, allowing the user to place the different components where he desires. The software usually comes with many features such as auto-routing, and annotations. These features can really help to finish the design faster, but from time to time there are errors; for example, when there are overlapping traces, which is when the user must make a decision and route them properly.

There are many different types softwares that can be used to design the printed circuit board. The free EAGLE version of the standard EAGLE software was chosen. The standard EAGLE version, cost a few hundred dollars, which is why we prefer to invest into better components than to be able to design a bigger or with more layers printed circuit board. Even though, EAGLE isn't the software with the best interface for the user, it is used by a vast amount of the community. This results in more components being available that we are able to choose from, as well as providing more support in the case a problem comes up. There are many tutorials out there, that can help understand EAGLE, due to the fact not being one of the software's that are not to user friendly.

Despite the many disadvantages of the free version of EAGLE, this is the only free software that allows to design a printed circuit board with up to eight layers. The other free versions of software such as DipTrace, and OrCAD can only allow two layers. In conclusion, the free version of EAGLE will suffice the needs to implement the circuitry designs for the Smart Cornhole, allowing the designer to create the printed circuit board to provide a superior overall project.

3.4.2 Materials in PCB

There are many layers in a printed circuit board. These different materials play a

role and combine together create a safer and better performing circuit board. The different layers are silkscreen, solder mask, copper, the substrate (FR4). The silk screen and solder mask are only available as the layer on both ends of the board (the first two top layers and the last two bottom layers). The copper and substrate layers are in the middle of the board, these layers can be set up alternatively, the copper layers conduct the electricity and the substrate provide the insulation between the copper layers. These different layers compose the printed circuit board allowing it to connect the components in such a reduce and organized manner.

The silkscreen is layer applied to the top of the printed circuit board. This layer aids with the identification of the connections to place the correct components in their place. It is use to provide the name of the components, test points, part numbers, warnings, symbols, and manufacturer logos. While you can design the printed circuit board with silkscreen on the solder side, this increase the manufactured price, due to this the silkscreen shall only be utilize when necessary to identify components and their values. While silkscreens are mostly use in white, the manufacture can provide a variety of different colors such as red, gray, black, and yellow. The manufactured company must be precise to ensure the silkscreen is aligned correctly with the components, as well perform in a clean environment to provide the best results.

The solder mask is placed between the silk screen and the copper layer. This layer is what gives the printed circuit board its green color. This layer is very thin lacquer like, that is applied onto the copper layer for protection from oxidation and to prevent bridges when soldering small connections that have the pin layout separated by a small distance. This layer not only aids the soldering printed circuit board perform by hand, but it also helps with the automated soldering from creating bridges between connections and solder jumpers. A soldered bridge is when two connections are accidentally connected when trying to solder relatively close together pins. The solder mask is a must have layer in a printed circuit board, it provides the board with durability from the elements while providing an easier to solder printed circuit board.

The copper layer is the main one, since this is the layer that provides the electrical connections between the components. This layer consists of a thin copper layer assembly with heat and adhesive. Complicated printed circuit boards can have up to 16 or more copper layers to suffice the design being made. The copper thickness can vary depending on the current that will be run through the electrical connections. This based on the copper weight in a square foot. Most of the printed circuit board are design with one ounce per squared foot, while there can be cases where a printed circuit board will be utilized with connections that require to run more power through them. These high power connections can be design with two or three ounces per squared foot, the more copper utilized in the printed circuit board translate to thicker copper connections within the printed

circuit board electrical connections.

Finally, the substrate (FR4) layer which insulates the copper layers from each other. This substrate gives the printed circuit board its thickness and hardness. The FR4 material is a glass-epoxy that are usually used in sheets, rods, tubes, and printed circuit boards. The FR4 is a flame resistant material, which discussed in the standards section for the UL-94 standard, which complies with it. The FR stands for flame retardant, which can extinguish a flame within seconds. The FR4 substrate has many qualities that has led to its popularity to be used in the printed circuit board design. Having flame resistivity and a strong electrical insulation help create a superior printed circuit board that can perform in both dry and humid environments, while still retaining its great characteristics.

3.4.3 PCB Design Recommendations

There are many ways to improve the printed circuit board to provide more reliability and durability. The printed circuit board is crucial component that must be perfect to provide better performance and ensure a long lifetime. This section will provide with basic precautions to take into consideration when designing the printed circuit board. Some of these techniques are general knowledge share by most designers, but it is still necessary to lay them all out. Moreover, these techniques will help create a printed circuit board as small as possible, which in an electronic system volume does matter quite a bit. The techniques will be explained in the following paragraphs.

The first technique is keeping the electrical traces a short and direct as possible. As the trace increase in length, it also adds extra resistance and inductance to the power and data lines. Short traces will improve the overall performance of the whole system, since it can reduce the performance of analog and high speed designs.

The second technique is to use a power and ground plane to manage all power needs for the printed circuit board. This allows the power to flow to all components as effective as possible. A whole layer of the printed circuit board should be made to be a power supply and ground plane. In addition, analog and digital planes should not overlap, meaning each must have it own plane.

The third technique is to use decoupling capacitors anywhere that will be necessary. Decoupling capacitors help deduce high frequency noise. Capacitors are inexpensive and reliable, which can help reduce the noise from the Bluetooth module to the speakers. Capacitors should be kept in a standard range to keep the necessary components within the same values.

The fourth technique is group similar components together. Similar components

are most likely connected together; this will allow them to be connected with minimal trace distance. This applies mostly to IC's, due to the fact that they need a bypass capacitor, and by grouping them together make use of the bypass capacitor to its maximum.

The fifth technique is choosing the best grid that will suit your design the best. The grid is an important tool to adjust when designing the printed circuit board, it will ensure that the electrical traces are able to connect to the right places. A big grid can make traces not being centered to the desire pad, which could cause a faulty connection. In addition, close pads such as in a one hundred pin microcontroller, the electrical trace can be between the two pads, which could cause an electrical trace to overlap between two pads. To conclude, the correct grid will decrease spacing problems and provide better electrical traces.

3.4.4 PCB Thermal Management

The printed circuit board is a very small and easily heated surface with all the components integrated on the board. Thus, proper measures have to be taken into account to make sure the printed circuit board doesn't overheat, since an integrated circuits life span is reduced the more heat it is constantly applied to it and continuously. Different components have varying levels of Heat that it shouldn't go over to avoid damage this is called the junction temperature (T_j). Making Thermal Management a very crucial part of increasing the lifetime of the Smart Cornhole.

There are many ways to try to manage the power dissipation of a printed circuit board such as using a heat sink, placement on the product, and a fan. A heat sink is a passive device that transfers the heat generated from a device in this case the printed circuit board even more accurately the voltage regulator which produces the most heat. Heat sinks come in many different shapes and sizes as well as materials since they can be made from many components that are great heat conductors.

Such heat sinks include well known materials such as copper, aluminum, and diamond. Everyone knows copper is a great conductor of heat and electricity used commonly in homes, computers and wiring of many devices but everything has a negative and for copper is that it is more dense and expensive than aluminum. The extra weight even though minimal is not wanted in the Smart Cornhole since it is already heavy as it is. Thus, Aluminum which is cheaper and lighter is a great second option even if it is a slower heat conductor it will be a great fit for the Smart Cornhole. Diamond is another heatsink

The placement of the printed circuit board can be very crucial as it can either help in reducing heat or add on more heat. A well-ventilated area is desired so the air

can help cool off the integrated circuits on the board. The printed circuit board is usually enclosed to protect it from any objects or anything really hitting it and causing a problem which makes the dilemma of keeping it in an open area for maximum contact with cool air. Thus, most add holes to any enclosure to allow more passage of air to the printed circuit board that is one method the other method is the fan.

Instead of allowing free air to allow some heat dissipation air can be forced around the printed circuit board to help keep the system cool. Fans are a really great way to keep heat down but they also consume energy themselves as the fan needs to be powered to operate. This causes more heat to be presented into the system which then has to be considered does it have a greater benefit or is the added heat more than what is cooled.

For the Smart Cornhole the way the board will be surrounded by all sides which means the inside will get very warm along with the fact that it is played outside which when in direct sunlight the surface of the game board would get very warm that could transition under the game board. Taking all this into account the thermal management for the Smart Cornhole will include an aluminum heat sink with designed with a lot of surface area in contact with the air for even better heat dissipation. The printed circuit board will also be placed under the board with holes on each side to have good ventilation and allow great air flow to cool down the system. A fan will not be added as it takes up space and power which is necessary for other parts on the Smart Cornhole.

3.5 Part Selection Summary

The table below shows an overview of all the various parts selected for the Smart Cornhole Project for a more in depth review of each part please refer to section 3.3 everything is well covered in that section.

Table 9: Part Summary

Item	Manufacturer	Part Name	Task
RFID	ThingMagic	M6E NANO	The Reader
MCU	Atmel	ATmega 2560	The Brains
Battery	Hitlights	3500 Ah	The Power Source
Bluetooth Module	Roving Network	RN-52	The Entertainment
LED Display	ChromeLED	Alzatex	The Referee
LED Strip Lights	Menzo	N/A	The Light Show
Xbee Shield	SparkFun	XBee Shield	The Communicator
Speakers	N/A	N/A	The Voice
Voltage Regulator	Texas Instrument	LM1084	The Regulator
Audio Amplifier	Texas Instrument	LM386	The Gains

4.0 Standards and Design Constraints

This section will present the various standards related to building a smart cornhole and how they will affect the design while meeting those standards. Moreover, this section will layout the design constraints related to the smart cornhole, reviewing how they will set back the design.

4.1 Standards

As newer technology is being discovered everyday, standards and government regulations have to keep up with newer technology to set the bar for newer products. These standards and government regulations will provide safety to customers who use the product. There are many standards and government regulations which apply to designing a smart cornhole. Some of the standards focus on communication and RF signals to prevent the interference with other electronic devices. Also, standards for power supplies and microelectronic circuits to prevent electric shocks to the users.

4.1.1 IEEE 802.15.4 Standard

Many standards have been professionally created by the Institute of Electrical and Electronics Engineers (IEEE). One of the many standards is the IEEE 802.15 which states specific regulations for a wireless personal area network. The Smart Cornhole will operate using two devices communicating on the same physical channel. Since the communication will happen for a small distance, the Smart Cornhole will fall under the category of IEEE 802.15.4, which consists of technology of Low-Rate Wireless Personal Area Network. This technology will suit perfectly in the implementation of the Smart Cornhole, since a low power technology is all that is necessary to transfer data between the two microcontroller units that will be used in this design. In addition, both of the two different RF ID readers will fall under this standard as well, since they use frequency to identify the tag within a certain distance from the main RF reader.

4.1.2 Power Supply

Power supply standards can prevent many hazard accidents from happening to the users, ranging from shock prevention to fire prevention. The power supply standards cover many possibilities by creating a standard to follow, which will prevent any damages or incidents from happening to the users. The standard is classified in a few sections. These sections vary to separate the different scenarios and the classes of equipment or components available to use which suit that

specific power supply. The following Table 9 shows the different sections for power supply (as specified by CUI, Inc.).

Table 10: Power Supply Specifications

Type of Circuit	Specifications
Hazardous Voltage	<i>Any Voltage Exceeding 42.2 Vac peak or 60 Vdc without a limited current circuit.</i>
Extra-Low Voltage (ELV)	<i>A voltage in a secondary circuit not exceeding 42.4 Vac peak or 60 Vdc, the circuit being separated from hazardous voltage by at least basic insulation.</i>
Safety Extra-Low Voltage (SELV) Circuit	<i>A secondary circuit that's cannot reach a hazardous voltage between one or multiple accessible parts while a fault is happening. In the event of a fault the voltage shall not exceed 42.4 Vac or 60 Vdc for a period longer than 200 ms. An absolute limit shall not exceed 71 Vac or 120 Vdc.</i>
Limited Current Circuits	<p><i>These circuits are accessible even if they exceed the specifications of SELV. The limited current circuit is design, so that incase of a fault condition the current being drawn is not hazardous. The limits are as follow:</i></p> <ul style="list-style-type: none"> <i>• Frequencies < 1kHz, the steady state current drawn shall not exceed 0.7 mA peak ac or 2 mA dc.</i> <i>Frequencies > 1kHz, the limit of 07 mA is multiplied by the frequency in kHz, but shall not exceed 70 mA.</i> <i>• Accessible parts shall not exceed 450 Vac or 450 Vdc with a maximum circuit capacitance of 0.1 μF.</i> <i>• Accessible parts shall not exceed 1500 Vac or 1500 Vdc with a maximum stored charge of 45 μC and available energy of 350 mJ.</i>

The design of the Smart Cornhole will fall under the category of Extra-Low Voltage circuit type, since the battery that will power on the whole system will not exceed 12 volts at the battery terminals. This voltage will then be distributed throughout the whole circuit, which will just decrease in magnitude as it goes into different components away from the battery. Minimal insulation will be use just to protect components from creating a short circuit from each other. The printed circuit board (PCB) will receive most of the insulation, since its where most components will be placed, this will protect the printed circuit board from creating a short circuit, prevent user interaction causing a shock, and finally prevent the possibility

of starting a fire from the components within the design of the Smart Cornhole prototype.

The standard is made for a specific reason, which is to prevent any sort of accident from happening to the users. Meeting this standard will play a big role in the design of the Smart Cornhole, since it will most definitely will be available to the public in a near future. Following the standard will give us the peace of mind of a well engineered product is out there being used, and is performing just as well. The standard will keep the designers free from liability issues that could occur, as well as having pleased customers enjoying the product while being in a risk free scenario.

4.1.3 Range of Available Frequencies

The US has a standard for the range of frequencies available to use to create a wireless personal area network standardized by IEEE 802.11. This frequencies standards are set for the unique purpose of keeping different wireless applications separated from each other. This isolation help prevent interference between the different applications that are using wireless communication. The available frequencies are as follow, 900 MHz, 2.4 GHz, 3.6 GHz, 5 GHz, and 60 GHZ. The Smart cornhole will need to use one of these sets of frequencies to wirelessly communicate between the two microcontroller units. The data needed to transfer isn't that great, since the only thing needed to be synchronization between the two is the score board and keeping track of the beginning or end of a turn. Following the standards will prevent our design from interfering into important frequencies ranges which can held the designers accountable for any interference that can be caused by our Smart Cornhole design.

4.1.4 IPC PCB Standards

The Association Connecting Electronics Industries (IPC) main concern is to standardize the production of electronic circuits and assemblies. A printed circuit board falls under this standard, IPC has many sets of requirements on to how a printed circuit board should be created, ranging from the different dimensions to the range of materials that should only be use in a printed circuit board. The standards ensure that the printed circuit board create will have a great lifespan and durability of its components. The range of standards are a follows general documents, design specifications, material specifications, performance and inspection documents, and flex assembly and materials standards. The IPC-2615 focuses on printed board dimensions and tolerances, which can play a decent role on designing the printed circuit board to meet dimensions that will at the same time fit with the Smart Cornhole design. Moreover, the IPC-2221 which lays out the generic standard on printed board design, this will keep the printed circuit board design under the regulation of this specific standard to create a more

reliable and durable printed circuit board to offer to the customers. Finally, the IPC-2223 states the sectional design for flexible printed boards, which set the standard for flexibility in printed circuit boards. There's many more standards that cover all the limitations for a printed circuit board that can be help keep the design under regulations to provide a more efficient and well established printed circuit board that will have a longer life span.

There are these many standards for a reason, to provide a better output product, which will increase the desired results in a printed circuit board. Following these standards will yield a printed circuit board that will be up to a standard to compete in the marketplace, which will last longer, give better performance, and be a safe product for any environment. In addition, an up to standard printed circuit board will keep the designers free from any liability issue that can occur to the users of the Smart Cornhole, giving the designers a peace of mind that the printed circuit board complied with all the design requirements to provide the best possible circuit board into the design of the Smart Cornhole.

4.1.5 NASA Soldered Electrical Connections

This soldering standard was created by the National Aeronautics and Space Administration (NASA) stating many procedures and regulations on how a proper soldering connection should be made. NASA states many requirements that need to be follow to ensure a reliable soldered connection, these are the requirements to be followed:

- A stress relief in the design to avoid thermal or mechanical stresses on the soldered connections.
- When a stress relief is not followed, then a plated-through hole (PTH) is mandatory.
- Materials selection to maintain any thermal expansion at the minimum on the parts that are being mounting on a certain configuration.
- Parts mountings shall provide a full visual inspection on all electrical connections that were soldered.

Some of the factors that play a role while soldering electrical connections are the facility cleanliness and environment conditions. NASA states in their standard that a soldering workspace shall be maintain clean and well organized. In addition, prohibiting a soldering workspace from smoking, eating, and drinking to prevent any kind of contamination to the soldering station. The only tools and materials that shall be at the work stations are those necessary to perform soldering between electrical connections. Furthermore, soldering electrical connections shall be performed in a control environment to maintain the soldered electrical connection under the same variable that provide a much stronger bond. This is necessary to keep the work stations free from contamination that could put at risk

any electrical connection performed in an environment that is not controlled. The temperature and humidity needs to be kept within the requirement limits of the “comfort zone” as stated by NASA in the following Figure 9, which shows temperature versus humidity requirements.

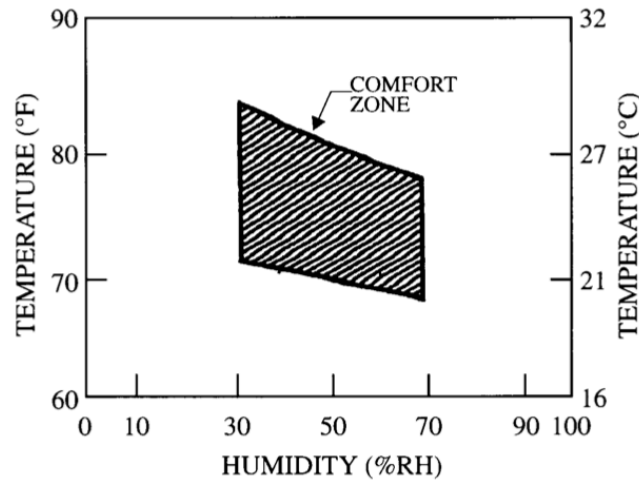

Figure 9: Comfort Zone Requirements. Permission submitted to use.

The tools necessary to perform superior soldered electrical connections need to be maintained and well clean. NASA states that the supplier shall use the appropriate tools to perform the job correctly and prohibits the use of defective or un-calibrated tools in a work space. In addition, the records need to be maintain of calibrations, detailed procedures, and maintenance of all the tools used in the workstations. NASA prohibits the use of soldering guns in this soldered electrical connections standard.

NASA sets many different scenarios when soldering electrical connections. Ranging from how leads should be place, stating the maximum separation allowed between the lead and the surface of the termination area. NASA gives a great explanation and procedure to follow in their standard to perform a superior soldered electrical connection. All soldered electrical connections need to be left to cool off at room temperature, no other source of cooling method is allowed, due to the fact that it can lead to fragile soldered connections or a bad fillet connection. The different variables that can cause a weak solder such as stress relief, insulation clearance, the mounting of parts on to terminals, and solder coverage. NASA states that to ensure every soldered connection an inspection of the solder should be performed after, which will ensure all connections are strong and perform up to the standard.

This is a great source to account for a standard, since NASA needs reliable and perfect soldering due to the fact that any faulty connections can cause a great amount of damage. When space exploration comes to minds, any defect in a

connection can be a great problem, which could not be solve easily due to the fact that the problem could be an enormous amount of distance away from them. This is why a standard from NASA has to be very tough, to minimize defects in soldering and create perfect soldered electrical connections. This is why implementing these soldering standard procedure in the Smart Cornhole will give the final product a much more reliable and durable soldered electrical connections that will last much longer than those that doesn't follow the standards. Providing a working prototype that will have better durability due to the strong soldered connections within the system itself.

4.1.6 Lithium Battery Standards

There's many lithium-ion battery standards that keeps the production of batteries strictly regulated to provided the users a safer battery to utilize. These standards are good to keep in mind when deciding on which battery to use for the design you are working on. The UN/DOT 38.3 is standard that focuses on testing any dangerous goods to approve them for transportation. Lithium-ion batteries fall under dangerous good category, therefore a good battery that is up to this UN/DOT 38.3 standard shows that it has approved various torture tests. The tests that a battery has to pass to be certified are altitude simulation, thermal test, vibration, shock, external short circuit, impact, overcharge, and force discharge. If a battery is certified by this standard, then the user can assume the battery can take a good amount of damage before it breaks down.

Another standard to keep in mind when deciding on a lithium-ion battery is the IEC 62133 focusing on rechargeable cell/battery testing. This standard has less harsh tests compared to the tests from UN/DOT 38.3 standard, but it can still be a good standard to keep in mind due to the fact that for this project the battery won't be exposed to a harsh environment. This standard realizes four test to the battery for it to be certified. The tests used by the IEC 62133 are molded case stress, external short circuit, free fall, and overcharging of the battery. Although these test aren't that difficult to pass, this standard will ensure a battery is ready to take day to day abused.

Lastly, the UL 2054 is another standard to keep in mind. The requirements of this standard are mandated for the United States for a number of devices. This standard is the most difficult to pass, since it performs about twice as many tests found in both the UN/DOT 38.3 and the IEC 62133. There is a total of seven electrical tests, four mechanical tests, four battery enclosure test, a fire exposure test, and two environmental tests. For a lithium-ion battery the electrical tests are the most challenging, involving a variety of short circuit, abusive overcharging, forced charged, and abnormal discharging. Passing these tests will ensure the battery is up to the UL 2054 standard, providing a battery that will definitely take any amount of abused in any system.

The Smart Cornhole will need a battery that is up to standards to provide the user a reliable battery that will work under any given condition. Any battery that is certified by any of these standards would work with the design. Having a battery certified by these standards gives the designers that piece of mind that the Smart Cornhole user has a reliable and durable battery. Most of the time the users put a battery to charge and forget about it, leaving the battery charging for hours. Even though, new chargers come with safety designs to cut charge going into the battery, there could be the smallest possibility the battery overcharging for hours. Therefore, having a battery that is standard certified for the design of the Smart Cornhole is a more suitable option.

4.1.7 Bluetooth Standards

Even if Bluetooth falls under the IEEE 802.15 standard, there is a few difference for Bluetooth that makes it different from a normal wireless personal area network. Bluetooth can be used in two different modes Bluetooth Basic Rate/Enhanced Data Rate (BR/EDR) and Bluetooth with low energy (LE). Bluetooth must have a few elements in its architecture such as RF transmitter, baseband and protocol stacks which allows for the exchange of data. The core system protocols are radio protocol, link control protocol, link manager protocol, and logical link control and adaptation protocol. These protocols create the Bluetooth controller which allows for the two-way communication. This controller can be set up to be BR/EDR, LE, or combined both BR/EDR and LE. In the case of the Smart Cornhole, BR/EDR will be implemented, since the main use for Bluetooth in the design will be the streaming of music. Bluetooth has been expanding throughout the years, as of now Bluetooth 5.0 was recently released and even though most devices do not contain Bluetooth 5.0, it is stated to be the same as Bluetooth 4.2, but with better performance, therefore Bluetooth 4.2 does not need to be replaced. This new Bluetooth 5.0 is twice as fast, four times the range, and eight times the data speed compared to Bluetooth 4.2. Implementing Bluetooth 4.2 into the Smart Cornhole design should provide enough performance, speed, and data for the features desired in the system.

4.1.8 UL 94 Standard for Tests for Flammability of Plastic Materials for Parts Devices and Appliances

The UL 94 standard is a series of small tests that evaluate the flammability of plastic materials for parts devices and appliances. The result of these tests gives the plastic a rating of ignition based on its characteristics. The results can yield two different ratings, which are HB and V (V-0, V-1, or V-2). To achieve HB rating, test samples of five-by-half inches are used. Then, the plastic sample is placed horizontally with the flame from a 0.75 inch 50W Bunsen burner flame placed at the

end of the test sample. On the other hand, to achieve a V rating (V-0, V-1, or V-2), the test sample is placed vertically with the flame burner from the bottom of the sample. In order to be classified under either of these ratings, the test samples must extinguish within a certain time, stay from dripping any material onto cotton indicators, or not burn all the way to the top clamp. To be applicable to this standard, the plastic material shall not exceed 13 mm in thickness or 1 meter squared in surface area.

The printed circuit board that will be implemented in the Smart Cornhole is made out of plastic, and falls under the dimensions to be classified for this UL 94 standard. Finding a good company to make the printed circuit board to meet this standard will be a fantastic addition to protection to the design. In order to meet this standard, a company that uses FR4 plastic, which falls under the UL 94 V-0 rating, must be employed to make the printed circuit board. This standard rating will ensure that in case of a fire in the printed circuit board, the burning will stop within 10 seconds, and will not drip any inflamed particles. This is a substantial standard to meet by the printed circuit board, since many components can exert a significant amount of heat due to the power consumption. In addition, a short circuit caused by any faulty component can commence a fire, having a printed circuit board made out of a material that can resist and extinguish the fire within seconds can help put out the fire, as well as not letting it surpass to any other components cause more damage to the system. To conclude, having an approved plastic by the UL 94 standard, will provide more protection from propagation of a fire started in the printed circuit board to the rest system, giving the customer a safer design that will have minimal damage in case of any fire.

4.1.9 Cornhole Approved Equipment

The American Cornhole Organization (ACO) is responsible for the rules and equipment necessary to have a certified cornhole. The American Cornhole Organization is an organization established in 2005, which started to offer official rules, tournaments and restrictions. According to the American Cornhole Organization to have a certified board, it must comply with a certain criterion. The criterion set by the ACO is a hardwood playing surface of two-by-four feet and minimum of half inch thick, each board weights no less than 25 pounds, the hole is placed nine inches from top and center from both sides, the diameter of the hole should be six inches on both boards, the front of the board is three to four inches off the ground and a foot at the back of the board, the playing surface must be finished with no blemishes to cause any disruption to the game, and the surface must be painted to provide a smooth finish allowing the bags to slide, but stay at its place when stopped. In addition, the requirements for the bags are simple to comply with, each bag is made from two fabric squares of six-by-six inches, which are made of a durable fabric, and each bag must weight between fifteen to sixteen ounces.

Since the Smart Cornhole is to be build from the scratch, it must comply with the standards set by the American Cornhole Organization in order to be a certified Cornhole. Having a certified Cornhole might attract more customers willing to use the Smart Cornhole in any type of tournaments, this will aid with keeping track of the score. A well performing Smart Cornhole could attract the eyes of technology savvy users who play this game in a competitive way, which could be a long shot but might be possible to implement the Smart Cornhole in competitive tournaments.

4.1.10 Design Impact of Relevant Standards

Standards and government regulations are enforced to provide a baseline for new products that may fall under each specific category. Implementing and following these standards and regulations can improve both the quality of the product and the safety of the user. In summary, all the standards discussed previously will affect the Smart Cornhole design in many different ways. The designers will ensure that all the required standards and regulations are met to provide a better quality design available to the market. These standards may require to upgrade to superior components or materials used, to provide a safer and more durable design. This superior materials or components will raise the cost of the design. This will ensure the designers conduct more research regarding the materials and components to ensure the best quality component or materials are being use, while still keeping the cost of the system at the lowest price possible.

Another impact created by the relevant standards and regulations is to ensure the designers practice and gain experience on the assembly and implementation of components. For example, soldering microchips onto the printed circuit board with up to standard finished connections is not an easy task. This would require a lot of practice from the designers to feel comfortable before attempting any soldering on the printed circuit board. Any small mistake could damage the printed circuit board, which will lead to more funds spent into replacing it. The main impact will lay on the designers due to the fact that they will need to practice for an exceptional amount of time before attempting any work on components that could be damage easily. This will retain the cost of the system at the lowest price possible, while providing the designers with a considerable amount of experience necessary for future projects.

Furthermore, there are standards and regulations that ensure the new product do not intervene with the performance of other technology that is already assign to specific tasks. For example, the range of frequencies available to create a wireless personal area network are set by the government to remove any interference between high priority frequencies and public frequencies. This will ensure the system is operating in the available frequencies to avoid any conflict with the law.

4.2 Realistic Design Constraints

In this section, the many different constraints that affected the design of this project will be discussed. The design constraints help bring the customers a more well-thought design, that delivers a better product based on the challenges set by the different categories of realistic constraints. These realistic constraints will ensure that more research is realized before attempting to buy parts or start designing the system. The realistic constraints will be approached individually, discussed the details of each of them, and how they will improve the design when these realistic constraints are applied or deeply thought for the Smart Cornhole design. These realistic constraints will improve the quality of the product, provide the designers with an enormous amount knowledge that can be apply in future projects, and a vast improvement to society quality of life, which can be break down into different categories as follows:

- Economic Constraints
- Time Constraints
- Environmental Constraints
- Social Constraints
- Political Constraints
- Ethical Constraints
- Health Constraints
- Safety Constraints
- Manufacturability Constraints
- Sustainability Constraints

4.2.1 Economic Constraints

The economic constraints will play an enormous part in the design of the Smart Cornhole. Unlike other semesters at the University of Central Florida, this semester senior design didn't receive any funding to provide the students help with the cost of their projects. Due to this fact, all the funding will come out of the student's pockets, unless they receive a sponsorship. In our team case, no sponsorship was acquired, which will leave all the funding for the project to be provide by the team members. This will play a big part in the design because, more research will need to be perform in order to minimize buying part that might not work out hen trying to implementing them in the design. The research will help minimize funding to keep it at a low range. For example, some components like the RF ID reader cost a substantial amount of money, leaving the team to research deeply into RF ID readers to bring the necessary components that will work flawlessly with the design. This economic constraint will eliminate the option of trial and error in some of the components, giving the team the only option to

deeply research before buying any component that cost an enormous amount of money.

In addition, to be able to keep the Smart Cornhole affordable to the market must keep the manufacturing cost as low as possible. If it was up to the team, the best performing components will be use to provide a better overall design, but since this is a project under a budget the parts must be chosen wisely, while still providing the required performance to achieved the specifications. This design constraint will create a decision to provide balance between quality of the product or an affordable design for marketability. The right balance must be achieved, to provide the customers the best quality components implemented in the design while keeping it at the lowest cost possible.

4.2.2 Time Constraints

Time constraints are probably the most important constraints in this whole section. This is due to the fact that the Smart Cornhole prototype must be completed and in working order by the end of senior design II to be able to present it to the staff. The total time is two semesters, which is about 7 months, since senior design two will be taken during the summer semester. The summer semester is shorter by four weeks than spring/fall semesters. This constraint gives the team a restriction on how many features and technology it can have implemented into the design. Most features such as implementing a solar panel to provide a renewable source to charge the battery while playing outdoors or adding proximity sensor to each bag, which will provide a way to eliminate the push button to keep track of the turns. This is the most important constraint to recall before making any addition to the overall design. The only way for extra features to be considered into the design is by having a working prototype that meets the requirement specifications before the end of the semester, giving the team extra time to figure out a way to implement more features into the design without affecting the already working Smart Cornhole prototype.

Under the administrative content chapter, the milestone section a schedule is provided with the most important events during the time available to design the working Smart Cornhole prototype. This schedule will provide the team deadlines for each event to be completed. This will keep the team on a tight schedule to help achieve the goals before the deadline. The most important event to consider is the Printed circuit board layout, which will require additional time to complete. The printed circuit board will require to design it and send the design to the manufacturer, which will make it and ship it back to us, this process will take about two to three weeks depending on time constraints on the manufacturer itself, meaning it must be allow additional time for a given scenario that the printed circuit board must be redesign or an accident occurs causing damage to the printed circuit board itself.

4.2.3 Environmental Constraints

Most people don't realize the damage new technology can cause to the environment. In the design of the Smart Cornhole, most of the components are harmless to the environment. Electricity is needed to power on the components to allow the prototype to work. Even if the Smart Cornhole would not need that much amount of electricity to work, it will still need electricity to perform. There's many ways that electricity is obtain, some do not affect the environment at all, but some do. For example, solar panels will not affect the environment at all, on the other hand fossil fuel power plants burn a lot of fuel to provide enough electricity for everyone creating air pollution. This air pollution affects the environment by cause global warning. This can be evaded or at least helped, if the team has enough time to implement solar panels to charge the battery. This environmental constraint will help the team take the initiative into designing a system that will require less power to function. More research will need to be performed in order to select components that will use less power and provide a more energy efficient Smart Cornhole without sacrificing performance.

Another environmental constraint is to provide the customers information of what to do in the case of replacing a battery. Most batteries are made out of toxic chemicals that can cause damage if get in contact with the environment. In addition, the mining of these chemicals to make a battery do cause damage to the environment such as global warming, resource depletion, and ecological toxicity. Therefore, since a battery is needed to provide a way to power on the Smart Cornhole, the constraint will be to research deeply into batteries to decide on one that is less damaging to the environment in the given case the battery isn't dispose property.

4.2.4 Social Constraints

The whole idea behind the Smart Cornhole is to provide the users a design with more features than the simple cornhole. One social constraint is to have a cornhole that is relatively easy to use. This will enable any person no matter age or language to be able to play using the Smart Cornhole. Creating a user guide will provide a set of instructions to follow on how to operate the system. This could range from turn it on/off, recharging the battery, troubleshooting problems, and a reset button incase the whole system needs to be reset.

Another social constraint is providing a system that should be available to everyone disregarding race, social status, and geography. Which would allow users to buy the product without any restrictions. Having an affordable system will help with this constraint, which will bring back many ideas talked on the economic side. Therefore, this constraint will encourage more research on the design to reduce the cost of the Smart Cornhole.

Furthermore, most customers will prefer a Smart Cornhole with good portability and storability. For example, having the rear legs fold back under the board will provide the customers an easier way to move it from one place to another, and take less room while storing it away after using it. Portability and storability are two constraints to keep in mind when designing the board itself, assuring that no electrical components will be in the way of the legs when folding them in. These constraints will ensure the designers accommodate the electrical components under the cornhole properly enabling the cornhole to have portability and storability.

4.2.5 Political Constraints

The only political constraint that will apply to the Smart Cornhole would be keeping up with new laws or government regulations on technology used by the design. Having the Smart Cornhole approved and certified by the many standards and regulations related to the technology used will allow the designers to put the Smart Cornhole in the market. This will provide the customers with an up to date system that follows government regulations.

4.2.6 Ethical Constraints

When it comes to ethical constraints, no harming components will be use in the design of the Smart Cornhole. User safety is an enormous concern to the designers, which is why no hazardous material or component will be used. On the other hand, no feature will be left out of the design in order to reduce the cost of the production of the system. All the features will still be available, while providing the lowest cost available to the users.

Furthermore, performing more research on the Smart Cornhole design to assure no existing patents are being violated by it. In addition, for any datasheet or figure used during the design and implementation of the system, proper permission shall be requested to ensure everything is performed the right way. This will avoid any future lawsuit or copyright problem.

4.2.7 Health Constraints

The health of the customers is serious matter that should have most priority. To accomplish a design that would not intervene or cause any health problems to the users. For example, most batteries are toxic to humans, animals, and the environment. This will ensure a battery less toxic is chosen to power on the design. There has been a great amount of research performed on lithium-ion batteries. Research have shown that lithium-ion batteries are not as harmful as

other batteries, which is why lithium-ion batteries have taken over the powering on almost all the electronic technology now a day. Furthermore, lithium-ion batteries are safer for customers as they do not tend to leak from the terminals as often as car batteries do. Even though, lithium-ion can still leak if they receive a small crack, they are safer and have better performance than other type of batteries. The battery is the only health constraints found in the system due to the other components do not have any effect towards the health of the users.

4.2.8 Safety Constraints

In addition to health constraints, there is safety constraints that should have top priority as well. There are a few safety constraints that play a big role when designing the Smart Cornhole. These constraints are electrical shocks, battery explosions, and fire prevention. Furthermore, even since these constraints might not look like a big deal to most of the public in the design of the Smart Cornhole, they should still be address to provide a safer design available and avoid any future problems with the law.

Electrical shocks can be fatal in a high voltage system, but in the Smart Cornhole voltage will not exceed 12 volts at the battery, which will be classified it as an extra-low voltage system. In this type of system, minimal insulation is required, but to provide the user a safer system, the printed circuit board will not be reachable without the proper tools. The battery shouldn't be able to shock the users when handling it to charge it. The only concern will be when the system is operating, a fault could cause excessive voltage to be produce, which is why the printed circuit board as well as all the other components shouldn't be reachable. This will prevent any electrical shocks to the users.

Moreover, batteries can be very harmful to both humans and the environment if they are not handle as instructed. A bad design battery can be really unstable, which can explode at any given time during usage. Batteries tend to produce heat when they are being used or charge. Batteries exploding mostly happen due to be designs within the batteries, where a part might overheat and it can't cool down quick enough, which creates a domino effect create more and more heat. This overheating can melting components within the batteries which can cause a short circuit in the electrical components. In addition, any physical damage can instigate an explosion as well. This will ensure the designers chose a battery that is up to the many tests set by the standards to ensure no battery will explode when using or changing the battery in the Smart Cornhole.

Finally, a fire can cause a great amount of damage to the system itself and its surroundings. If action is not taken quick enough, the fire can expand and deal a vast amount of damage to both belongings and the users themselves. Fires can be started due to components failures or short circuits within the system itself. In

addition, the board being completely made of wood can help a small fire burn for a while, giving it more time to expand and spread to its surroundings. This will help the designers select materials and components that are more fire resistant. For example, having the printed circuit board plastic being UL 94 certified will ensure fires started at the printed circuit board would not propagate and extinguish within seconds. Good quality components will ensure that components won't fail during a vast amount of usage taken. These safety constraints will bring peace of mind to the designers, knowing that a great design with superior components was implemented into the Smart Cornhole.

4.2.9 Manufacturability Constraints

Manufacturability constraints will ensure a new design will be able to be produced rapidly without many limitations. Since we plan on selling it to the public and in the case of the demanding increasing rapidly, having the manufacturability already implemented in the design will prevent from redesigning the whole system once again. To be able to have the design with manufacturability, certain components must be selected to enable the manufacturability in the design. Components that take a big part in the design such as the RF ID reader and the microcontroller, must be selected with precaution. Taking into consideration how old is a component, perhaps the component could be discontinued and only a number of them might still be out there for a period of time. When ordering components it's important to look how many are in stock available to buy to the public. In addition, selecting components that are very popular can help, due to the fact that since they are popular, the components will still be made since they sell a lot to the public. Having manufacturability implemented into the Smart Cornhole will save valuable time to the designers in the case of an urgency to implement a vast amount of systems.

4.2.10 Sustainability Constraints

Sustainability constraints for the Smart Cornhole can determine how long it could stay alive in the business market, and the durability of the system under severe environmental conditions. Since the cornhole is a game that most of the time is played outdoors, heat can really put a lot of stress to all the components. The Florida weather in the summer time can get over one hundred degrees Fahrenheit, combined with the heat produced by the components being used can accumulate to a vast amount of heat. This can put the components under a lot of stress, which if they are not selected precisely can lead to a component failure, which could escalate to a worst problem. Sustainability constraints can help the designers select components that are going to be able to perform under these stressful situations. To overcome this constraint successfully, the designers must select components that are able to operate on higher temperatures. In addition, design

the Smart Cornhole using components that would not dissipate as much heat, keeping the design from overheating.

To keep the Smart Cornhole alive in the business market, many factors must be considered to ensure the Smart Cornhole would not die and be forgotten quick enough. The main factors are performance, durability, and cost. These factors play a crucial role on attracting customer to buy the system. If at any given case someone else decides to compete with our design, and come up with a better design, better measure must be taken on our end to implement newer technology, which could lower the overall cost of the Smart Cornhole. Basically, to maintain the Smart Cornhole alive, the design should be updated with the new technologies being release to provide the customers with the top notch available technologies at that specific time. Cornhole being a fun game or sport to play for all ages, which can lead to the conclusion that the game would probably never died as a whole. Therefore, the business market for the Smart Cornhole will always have customers willing to purchase it.

5.0 Project Design Details

This section will outline the details of our Project's overall setup. What this entails are the physical components of the setup and the software component of the setup.

5.1 Microcontroller Details

The microcontroller board that we decided on using is the 8-bit Arduino MEGA 2560 microcontroller board. This board is based on the Atmel ATmega640V-2560 microcontroller. We chose this particular microcontroller board because it features 54 digital general purpose input/output pins with 15 of those pins having pulse width modulation capability. It also has 16 analog inputs in case we wanted to utilize a component that only works with an analog input. Serial communication is available on this board in the form of 4 Universal Asynchronous Receiver/Transmitter ports. The board has 256KB of flash memory so we can store even the largest of code. The clock speed of the crystal of the chip on board is 16Mhz which is fast enough for our requirements. This boards' operating voltage is a mere 5 volts, this meets our low operating voltage needs. The board supports any Arduino compatible shields, which are hardware functionality extensions. The microcontroller board is equipped to handle Arduino Software, the high-level language closely related to Processing/Java.

The microcontroller board has onboard voltage regulators that we will be using during development to get the required DC power. As our testing comes to an end, we will be replacing the microcontroller development board in favor of a custom PCB with all components integrated. This will include the microcontroller chip on the PCB. The PCB is detailed in a section below, but will generally include all the small components necessary to have a working microcontroller.

5.2 Power System

The power system is very important part of the design, since it will power up every component in the system. The power system ensures that every component get the voltage based on the data provided by the component's manufacturers. This voltage shall be within the recommended range provided to ensure the components don't fry or short circuit, if more voltage of current is applied that the component can handle. The voltage regulator will ensure that incase the battery discharging giving voltage larger than the recommended voltage. This could cause a lot of damage, which is why the regulator will ensure that no surge of high voltage or current flows in to the major components of the system.

The following block diagram shows the overall power system to power the different components of the Smart Cornhole. The Smart cornhole will run off a 12V DC input provided by a battery with enough capacity to power on all components for a decent amount of time. This voltage from the battery will then go into a regulator that can be adjusted based on the resistor used. The first regulator will regulate the the voltage at 5 volts. This 5 volt output will power on both the microcontroller unit and the RFID reader. Using the same input 12V DC voltage from the battery, another regulator will yield an output voltage of 3.3-volts, which will be used to power on the Bluetooth module for the wireless speakers and the ZigBee module for the wireless communication between the the two microcontroller units. In addition, a regulator to provide an 8V DV output voltage, this will be used to power on the LED seven segment displays. The displays can take a range from 8-10.2 volts. Having an 8 volts input for the display will enlarge the lifetime, due to the fact that the displays aren't not operating at the absolute maximum input voltage. For every LED segment, a current limiting resistor will be needed, this resistor will ensure that the require current is allowed through the LED segment. Finally, to provide an USB charging port for the users, the charging port will need a 5-volts regulator to power it on, this will receive an input from the same 12V battery and regulate it to 5-volts. In addition, it will require a current of 0.5A which will be ensure by implementing a resistor to regulate the current for the charging port.

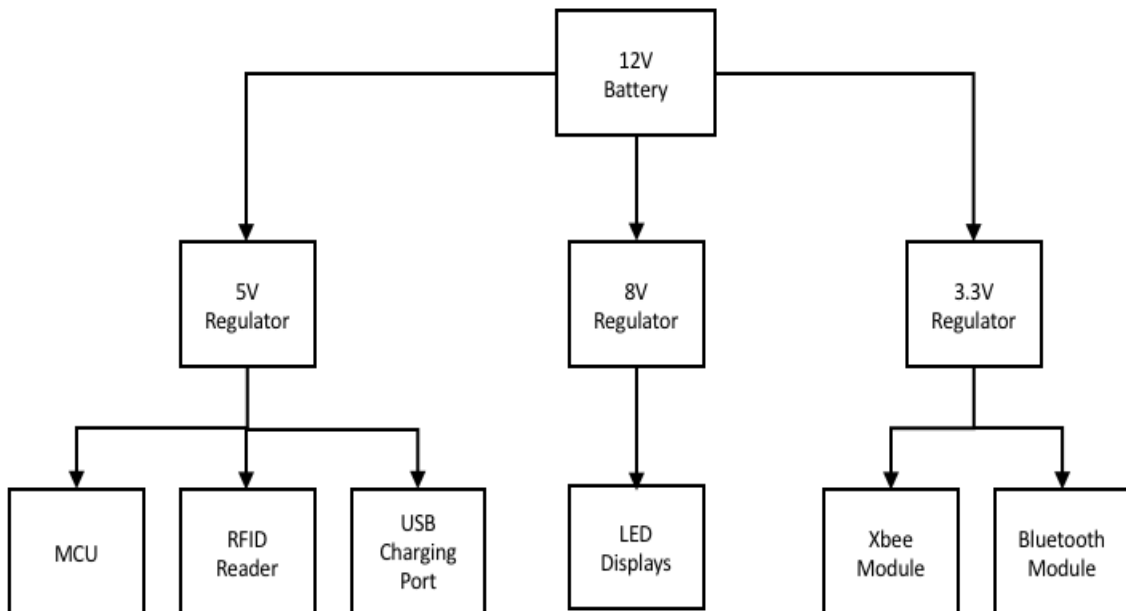

Figure 10: Power system of the Smart Cornhole

The regulators that will be used in this system are LM1084 supplied by Texas Instruments. This regulator is a low dropout voltage regulator, which leads to not a lot of voltage is drop by the components inside the regulator. The less the voltage drop yields less heat the components will dissipate, keeping this regulator from overheating. This regulator can be adjusted based on the resistors implemented in the design. This regulator can receive an input voltage of range from 2.6-29 volts, giving it a widely range of different options to decide on a battery pack. The output voltage from this regulator can be adjusted based on the design of the circuit by choosing the values of resistors, these ranges vary from 1.25 to 27.5 volts. The three different regulators will have different resistor values to provide the different output voltages based on the following formula provided in the datasheet of the regulator:

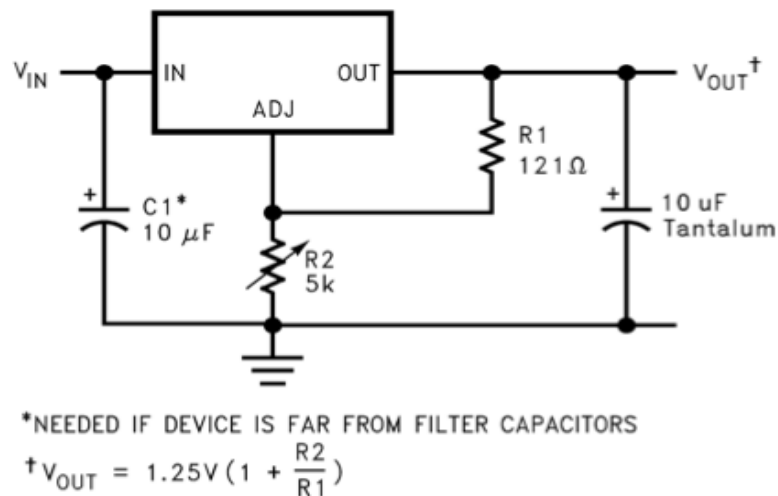

Figure 11: LM1084 Schematic with Formula. Permission Granted Courtesy of Texas Instruments

Using this formula to derive the resistor values based on the target output voltage for each of the regulator. The first regulator is aim to provided a 5V output voltage, which lead to ratio between R2 and R1 to be 3, giving the option to pick R1 to be 121ohm and R2 to be 365 ohms. For the second regulator, to provide a 3.3 volts output voltage the ratio between R2 and R1 will have to be 2.65. This will yield resistor values of R1=121 ohms and R2=200 ohms to be implemented into the design. For the third voltage regulator, to adjust the regulator at an output voltage of 8 volts, the resistor ration must be 5.4 between R2 and R1. This ratio will give out resistor values of 650 ohms for R2 and 121 ohms for R1. These regulators will yield the desire voltage to regulate at, to provide the different components the needed voltage to work properly. Moreover, every component can only tolerate a maximum current, these regulators will provide a current that can be determined by the load of the device, adding a resistor to in series to limit the current going into the component to input no more than the desire current.

Furthermore, the regulator will provide the major components protection in case of a high voltage surge coming from a failing battery. The voltage regulators will ensure up to 27.5 volts, coming as an input from the battery and regulating them down to 5 volts, and 3.3 volts to provide the components the voltage within their operating range. This will ensure the high voltage surge coming from the battery doesn't damage any of the major components of the battery. The major components such as the microcontroller unit, the RFID reader, Bluetooth module, and the ZigBee wireless communication module; any damage to any of these components will result in major repair cost, or replacing cost from damaging components.

5.2.1 Power Details

Table 11: Estimated Component Power Draw

Component	Operating Voltage (Volts)	Active Operating Current (Milliamps)	Active Time (Estimated, Seconds per Minute)	Full Time Power Draw (Watts)	Estimated Real Power Draw (Watts)
Arduino ATmega 2560 Microcontroller	12	35	60	0.425	0.425
Xbee 1 mW Series 1 Module	3.3	45	60	0.1485	0.1485
Sparkfun M6E RFID Reader (ThinkMagic Nano)	5	640	1	3.2	0.05 + 0.84 (Ready Mode)
7-Segment LCD	2.95	100	60	.295	.295
USB Power Port	5	500	60	2.5	2.5
Total Estimated Real Power Draw (Watts)					4.2585
Battery Capacity (Milliamp Hours)					3500
Estimated Runtime (Hours)					~8.22

We will be using a 12-volt exchangeable and rechargeable battery pack that was originally meant to be used with various power tools. The pack has a brand-based standard secure physical locking mechanism that we will be cloning. The cloned docking design will be implemented in our game-board design. The battery we selected will have 3500 mAh in capacity. The following calculations will be based off that figure.

So, with a 12v battery that has a capacity of 3500 mAh, we have a safe estimate that if the game were to be played to perfection, that the battery will last over 8 hours. If we were to acquire and use a battery with a 7000 mAh capacity, the run time would effectively be doubled. This is more than enough for a day's worth of fun using the Smart Cornhole system for tailgating or other events. Most tailgating is not 8 hours in length.

5.2.2 Power Distribution

Power will be distributed from a central point starting from the battery. From there, a switch will control the on/off flow of power. After the power passes the switch, it is then modified by three voltage regulators that will step down the voltage to 8,5, and 3.3 volts. The 8 volts is for the seven-segment display, the 5 volts is for the microcontroller and RFID reader, and the 3.3 volts is for the Bluetooth module.

5.2.3 USB Power Port

We will be including a USB Power Port on the game board in order to power any accessories such as an external Bluetooth speaker, should a player decide he wants to use one, or a cell phone charger. This port will supply at minimum 500 milliamps of current at 5 volts. This is the standard amount of power that a regular USB port would provide from a desktop computer.

5.3 Wireless Communication

For wireless communication, we will be using the ZigBee protocol, or colloquially, Xbee. We chose this mainly because it offered a low power solution to a wireless serial channel. For the game state reading, we chose to go with Radio Frequency Identification, which offers the range and capability, all while remaining low on power consumption.

5.3.1 ZigBee for Wireless Communication

ZigBee is the wireless protocol that we will be utilizing for the game setup. ZigBee is based on the 802.15.4 IEEE specification for wireless communication. What ZigBee allows us to do is create personal area networks, furthermore, it works

with low power applications. It is quite like the 802.11 specification of wireless communication that we know, but has some major tuning; where ZigBee excels is that it is easier to use and is much less expensive than other alternatives in the market right now.

The range on the 1mW Xbee Series 1 module we have selected for use is up to an astonishing 300 feet in the most ideal of situations. This will give us no issues with range considering the game board is no more than 30 feet (depending on the specific game rules) away. We won't be using more than 2 ZigBee modules, but if there was ever a necessity for more range, ZigBee modules can be daisy chained over a mesh style peer to peer network for more range. We won't need that particular advantage, though. We only need to circumvent potential radio frequency interference in the form of aluminum foil. This will be talked about further in this section.

Table 12: 1mW Xbee Series 1RF Module

1mW Xbee Series 1 RF Module	
Specification	Value
Indoor Range	Up to 100 ft.
Outdoor Line-of-sight Range	Up to 300 ft.
Transmit Power	1 mW
Data Rate	250,000 bps
Serial Interface Data Rate	1200bps – 250 kbps (non-standard data rates are supported)
DC Supply Voltage	2.8-3.4v
Transmit Current	45 mA @ 3.3v
Idle Current	50 mA @ 3.3v
Power-down Current	< 10 uA
Supported Network Topologies	Point-to-point, Point-to-multipoint, and Peer-to-peer
Addressing Options (for network setup)	PAN ID, Channel, and Addresses

The data rate at which ZigBee transfers is 250 kbit/s, which is more than enough for our application since we will not be doing any sort of large data transfer. In fact, we will be doing minimal data transfer that only includes the identification numbers for the RFID tags we will be using, the signal strength that tag is read at, and the transfer of commands from the console. We estimate that no more than 10% of the available bandwidth will be used at any given time. Bandwidth was never a concern when we were selecting a wireless solution to use.

To setup the ZigBee network, a ZigBee explorer is required. What this enables us to do, is to perform the discovery and first time setup between modules. This will require the use of a full-fledged computer system running Windows or Macintosh OS as the operating system, with an available USB port. Once we plug in the ZigBee explorer into the computer, with the ZigBee Module inserted, it's time to configure using the X-CTU software. Using X-CTU software, we need to add the devices to the device list. Then after adding the devices, we must configure them to run on settings that are not the default settings. This is because, out of the box, ZigBee modules are configured to all run on the same settings. This poses the threat of outside interference if there is another ZigBee setup within the operating range. A few of the available settings to modify for this are: Channel, Personal Area Network ID, ZigBee MY address, and Destination Address. A combination of these will result in a proper network configuration that does not have any interference with other ZigBee networks within range.

For development, we will be using the stated 1mW ZigBee Series 1 modules mated with an Arduino compatible stackable ZigBee shield. These will later be integrated on the printed circuit board design along with the other components. This setup will allow for easier and quicker development in the case that we end up being time limited. The ability to quickly attach and detach a module such as ZigBee will prove invaluable.

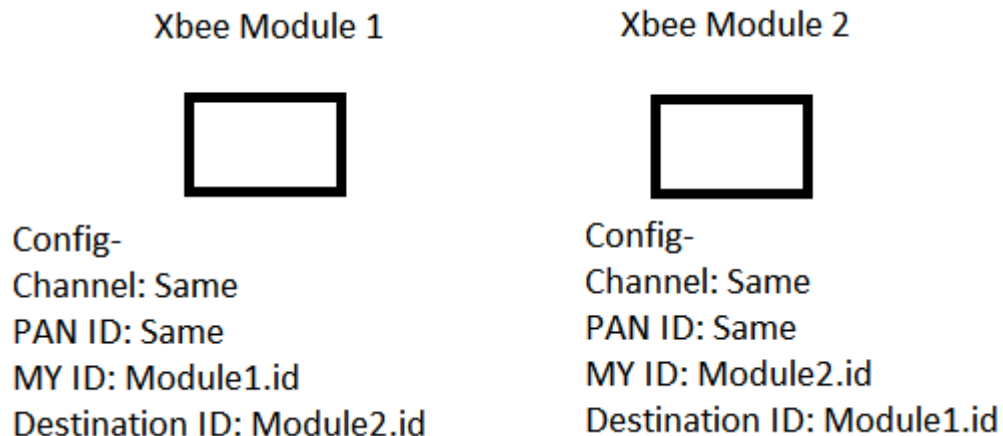

Figure 12: Xbee Configuration

The Xbee module that we are using will need to be positioned carefully outside of the Aluminum foil layers. Since the foil is a direct impediment to all radio frequencies, we need to place the Xbee module in the front of the game board with direct line of sight to the console, ideally. This leaves the module to be placed in the front of the game board, outside of the foil layers but in a secure location such that no bean bags will come into contact with it. The force of a beanbag impact could potentially destroy the fragile Xbee module.

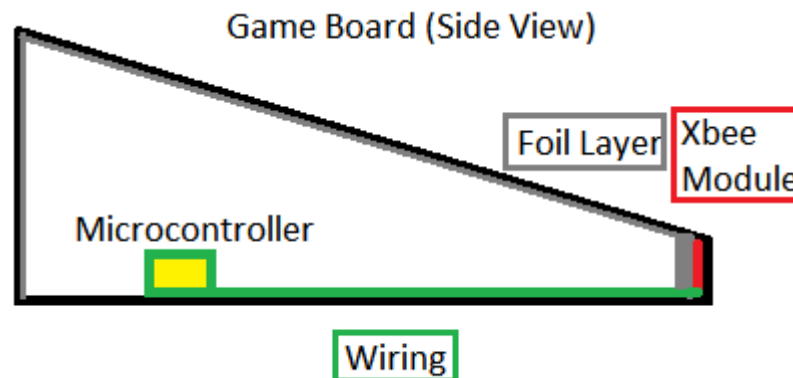

Figure 13: Xbee module

5.4 RFID Specifications

We will be using Ultra-High Frequency Radio Frequency Identification (RFID) modules and tags. We decided to use Ultra-High Frequency (UHF) RFID because it offers long range capability, lower cost, and intuitive passive tagging.

The module we will be using is the ThingMagic Nano, which is an embedded UHF RFID Module. The module will be mated to the SparkFun Simultaneous RFID Reader M6E Nano board. This module is capable of reading and writing to tags. The supported RFID Protocol is EPCglobal Gen 2.

The ThingMagic Nano RFID module fits the bill nicely. With very low DC Power Requirements, we can run the module for a very long time with our power supply. With a boot-up time of under 30 msec, it will be very quick for the end user to get up and running. With the capability to read 200 tags per second, there will be no reason why the game cannot be as fast paced as humanly possible.

The next major selling point when choosing this RFID Reader Module is the ability to determine the signal strength of the tag being read. This will allow us to determine whether we can count a beanbag as in the play zone or outside of the play zone. With clever use of Aluminum Foil, we can essentially close the play zone off, such that the game board is the only zone considered "in-play", and

zones that are not on the game board, will be out of the countable area. Radio frequency waves have a hard time penetrating metal surfaces, and aluminum foil is flexible, and can be adjusted in various ways into blocking strength dependent on the layers used. When aluminum foil is applied to the undersides of the game board, those wooden sides outside of the game board can be turned into very effective signal blockers.

Table 13: ThingMagic Nano

ThingMagic Nano	
Specification	Value
RFID Protocol Support	EPCglobal Gen 2 (ISO 18000-6C)
Antenna	50 Ohm (board-edge)
Power Output (RF)	Adjustable 0dBm to +27 dBm (0.01 dB increments)
Frequency Bands	917.4-927.2 MHz (North America, FCC)
DC Power Requirement	<ul style="list-style-type: none"> • DC Voltage: 3.3 to 5.5 V for +25 dBm out 3.7 to 5.5 V for +27 dBm out • DC power consumption when reading: 3.2 W @ 5 VDC for +27 dBm out 2.9 W @ 5 VDC for +25 dBm out 1.5 W @ 5 VDC for 0 dBm out
Idle Power Consumption	<ul style="list-style-type: none"> • 0.84 W in ready mode • 0.015 W in sleep mode • 0.00025 W in shutdown mode
Boot Up Time	< 30 msec
Tag Reading Performance	200 tags/sec

The RFID tags that we will be using are Electronic Product Code Class Global Generation 2, or EPCglobal Gen 2, Tags. What this means is that they can be read if the reader works within the frequencies of 860 MHz to 960 MHz. In North America, the Federal Communications Commission, or FCC, have specifically stated that the available operating frequencies of RFID are 917.4-927.2 MHz in order to comply with the EPCglobal Gen 2 tags. While the tags do have read and

write capabilities, we are only interested in reading the tags. Each tag will have a specific Tag Identifier, or TID. This value is read out to the RFID reader every time the tag is read. The reader will access this TID value along with the relative signal strength value.



Figure 14: RFID Tags (Same tags programmed for different teams)

The signal strength is measured in decibel-milliwatt, or dBm. This is a measurement based on the decibel in relation to the output in milliwatts. Since the onboard antenna of our RFID module is a single 50 Ohm connection, we can take the measurement of 0 dBm to mean the power level that corresponds to 1 milliwatt (mW). This follows that a 10 dB increase in power level will result in an increase of 10 times to the power (10 mW). More importantly, we need to see the effect of the decrease in level. This is more application specific as we are reading tags that are further away and that results in a lower power level. So, as an inverse example, reducing the power by 3 dB, will result in a power that is one half of the original value. So -3dB is the equivalent of 0.5 mW. Signals that are unreadable are expressed as -infinity dBm rather than a 0-watt power value.

Aluminum Foil has strong radio frequency blocking capabilities. The use of the foil in layers has great effect on blocking the RF waves that are used to read each tag. By using the foil in multiple layers on the side of the game board we can greatly reduce the efficacy of the RFID readers range for reading on the outer sides of the game area. By using less sheets of foil directly underneath the game board, we can block less of the waves such that the final signal strength that is read from the tags is somewhere in the middle. We want the signal to be strong enough to be read but at the same time we don't want to confuse the signal strength with that if a tag that has fallen through the middle 3-point hole. The code

that we write will include a sort of filter that will determine the final scoring mechanism. The hardware will require calibration and extensive testing to be completely accurate.

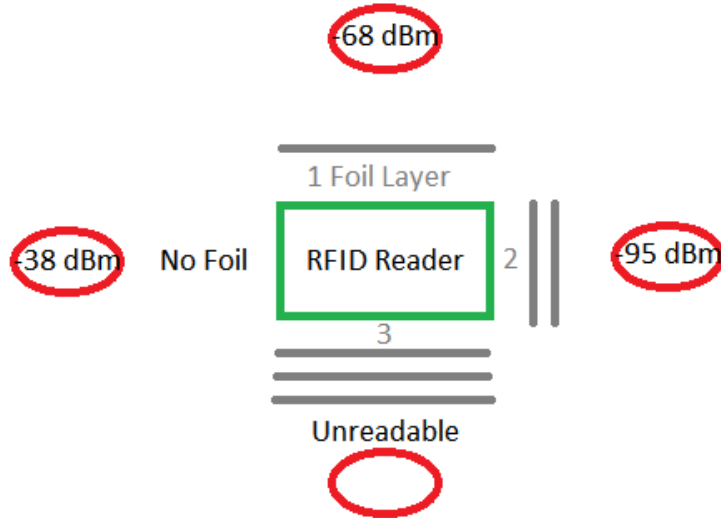

Figure 15: Effects of Foil

The figure above is an example of the expected outcomes of applying aluminum foil in layers. These are not accurate numbers, but rather just expected numbers. The number of layers of aluminum foil required may vary greatly and may have to be adjusted after testing. The final objective is to achieve the greatest radio frequency blocking potential, in order to make a tag unreadable outside of the game's "in-play" zone.

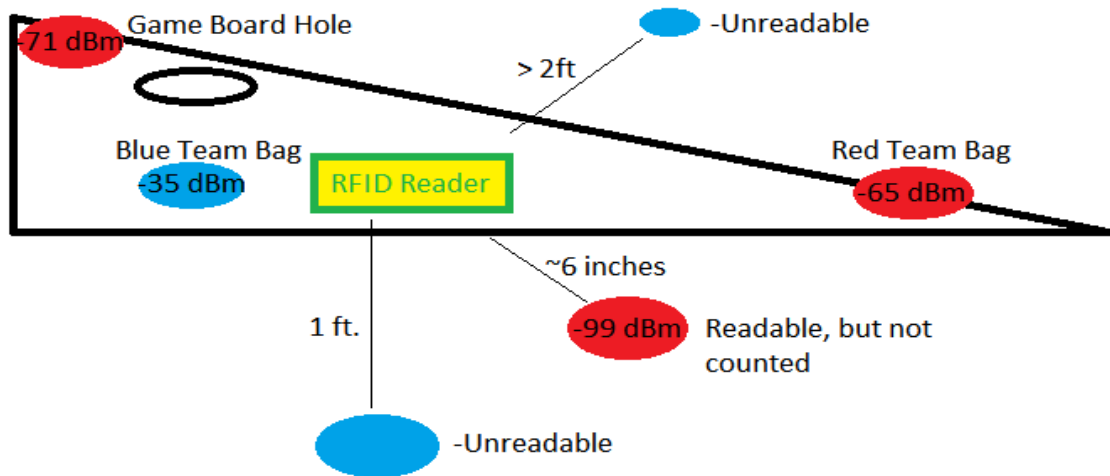

Figure 16: RFID Reader detection

The signal strength will be displayed as a value that is a ratio between the tag being read with the highest signal strength to one read with the lowest strength. This will determine how far away any tag is in relation to those first two measurements. For example, if the signal strength noise floor is -100 dBm, and we determine that the furthest possible reading is measured at -99 dBm and that the closest possible reading is -35 dBm, then the relative signal strength will be value between -35 dBm and -99 dBm that will determine the placement of the RFID tag being read. This will not be an extremely accurate measurement of distance, but it will do just fine as we are only trying to read the tags that are either on the gameboard or underneath it. As the rules of the game state, any bags that land outside of the countable zone are considered “misses” and have no score value. The bags that land on top of the game board will see a reduction in signal strength and will be counted as a single point. The bags that land in the hole will fall through and will produce the highest signal strength seeing as there is no obstruction between the tag and the reader whilst underneath the board; these bags will count as 3 points.

5.5 Display

The Liquid Crystal Display (LCD) that we will be using is a 7-segment display that is easy to drive (in terms of power), and easy to view in indirect sunlight. The requirement is that the display have enough digits to display the score for both teams. It also must be big enough physically, such that it can be viewed from 30-40 feet away. A major specification that would swing an “on the fence” decision is the ability to have multiple colors displayed at once. This would mean that Team #1 and Team #2 would have separate colors displayed on a single 7-segment display.



Figure 17: Ideal 7-Segment Display Setup

Each of the seven segments has its own individual activation parameters. In our case, the segments are active low and the display is common anode. This means that the power is supplied on 2 of the pins, and the remaining 8 pins are dedicated to each of the sections. The display has an extra segment for a decimal point but

we will not be using that. The segments are separated into a,b,c,d,e,f,g each corresponding to a piece of a digit. As each section is individually lit, it is necessary to modify the design to fit this specification. If we were to utilize 7 pins from each display, we would need a total of 28 pins to drive 4 separate displays. This pin count is too demanding for our microcontroller, so we are deciding to use a decoder in order to reduce the required pin count. Each decoder will drive a single display and each of its seven segments. We will be using 4 decoders, each will 4 input pins, which gives use a total of 16 pins in use. This is 12 pins less than if we were to skip out on using any decoders.

5.6 LED's

We will have strips of LED's on the game board. The main objective of having these LED's is aesthetics and to help with playing the game in low light situations. We will be using cut down strips of 3528 SMD LED's that are originally 5 meters in length. We chose 3528 LED's because they are more energy efficient than 5050 LED's and provide sufficient brightness. We will be further reducing the power requirement by running them at a lowered voltage. These strips will be cut to length along the necessary sides and hole of the game board.

5.7 Console Hardware Design Details

We will be building a console that sits next to where the beanbags are thrown from. This will serve as a marker to let the players know where the safe distance to throw bean bags from is. This console will include another Microcontroller primarily as proof of concept across two potential game boards. The decision to only have a single game board is driven by market cost of the finished product, which would have otherwise utilized two RFID modules, which almost doubles the cost of playing the game. The console hardware setup wirelessly controls aspects of the game such as signaling end-of-round, and restarting the game if needed. The console also serves as a proof-of-concept that we can actually create two working game boards, but the only thing stopping us is a reasonable price for a set of game boards both with RFID reading components. So, with this, we decided the best way was to create a separate console that says that we are able to, but due to restrictions, decided not to create two separate game boards.

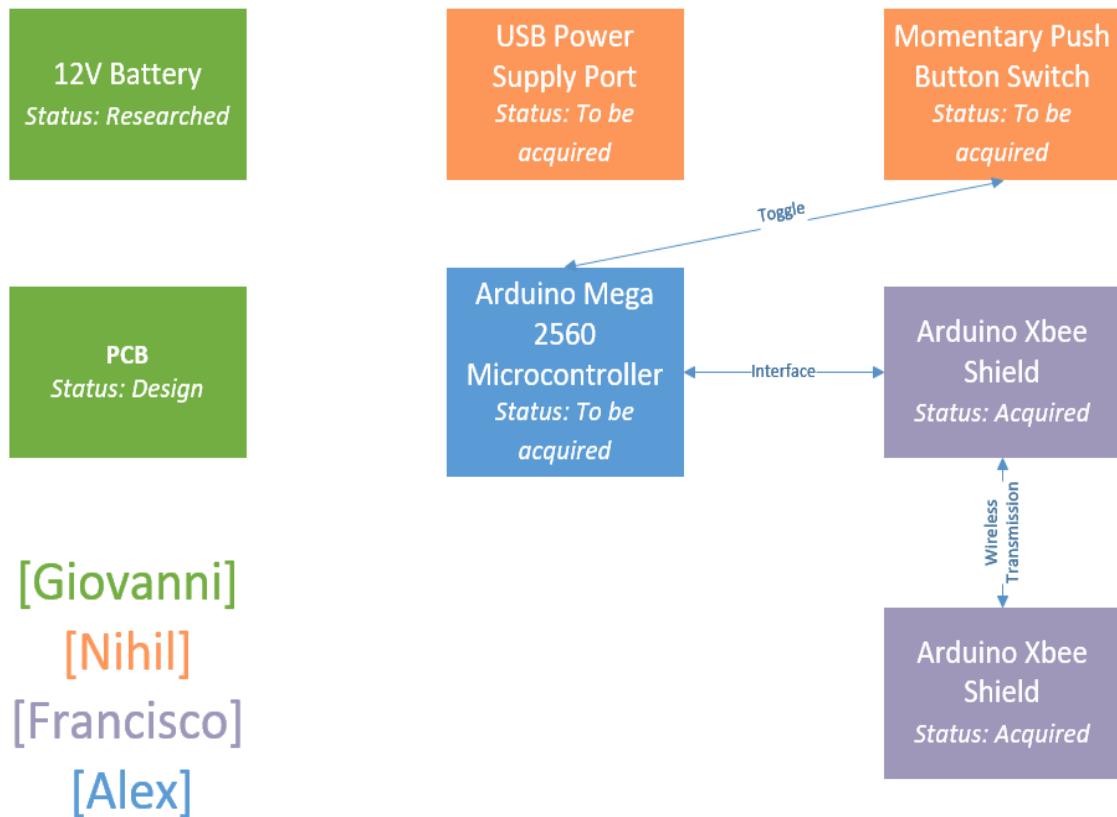

Figure 18: Console Hardware

5.7.1 Console Microcontroller

The microcontroller board that we are using for the console is the same 8-bit Arduino MEGA 2560 microcontroller board that we are using for the main game board. The duty of the microcontroller in the console, is mainly to communicate with the other Microcontroller (game board) via ZigBee communication, and to relay information about the momentary toggle switch.

5.7.2 Console Wireless (ZigBee)

We will be using the same 1mW Xbee Series 1 module as the game board setup. This is to ensure complete compatibility, even if another type of Xbee module was compatible, we would not want to take the chance. In this case, we are dealing strictly with Module 2 and therefore the configuration will have the same Channel, PAN ID, MY ID as the ID of Module 2, and the Destination as Module 1.

5.7.3 Console Button

There will be a momentary push button switch installed on the console and hooked up to the local microcontroller. This button will let the remote microcontroller of the game board know when it is safe to count the bean bags and tally the scores. After both teams are finished throwing the bean bags, the button will be pressed for just a moment, this will initiate the scoring code to execute on the game board.

There will be another function to the button, so that if ever the players require a total restart of the game, it can be done without having a separate button. When the button is depressed for 3 seconds or more, the command for a game reset will be sent instead of sending end-of-round.

5.7.4 Console Power

The console will have its own power requirements since it is a separate system. While it does include some similar components, it does not have as many of them as the game board does, and therefore will draw less power than the game board. We can assume that both battery packs will be charged to 100% capacity before use.

5.7.4.1 USB Power Port

We will have a USB Port on the console mainly meant to supply power to the Bluetooth speaker. This port, like the port on the game board, will supply at minimum 500 milliamps of current at 5 volts. This is still the standard amount of power that a regular USB port would provide from a desktop computer.

5.7.4.2 Battery

Based on Table 15 this puts the runtime estimate for the console at well over 13 hours of runtime, with the consideration of playing the game perfectly. We always have the option of choosing a battery with a larger capacity, though that would be completely unnecessary as 13 hours of game time is an entire 5 hours of game time more than our game board.

We will be using the same exact battery as in the game board. This is likely to remain a 12 volt, 3500 mAh battery. Redoing the power calculations for component changes seen in the table above.

Table 14: Battery Draw

Component	Operating Voltage (Volts)	Active Operating Current (Milliamps)	Active Time (Estimated, Seconds per Minute)	Full Time Power Draw (Watts)	Estimated Real Power Draw (Watts)
Arduino ATmega 2560 Microcontroller	12	35	60	0.425	0.425
Xbee 1 mW Series 1 Module	3.3	45	60	0.1485	0.1485
USB Power Port	5	500	60	2.5	2.5
Total Estimated Real Power Draw (Watts)					3.0735
Battery Capacity (Milliamp Hours)					3500
Estimated Runtime (Hours)					~13.65

5.8 Hardware Schematics

In this section, the Hardware schematics will be introduced. It is important to note that there's going to be three different schematics for the three main designs, the main microcontroller with RFID reader, the microcontroller in the module, and finally the Bluetooth module for the wireless speakers. Each of the schematics will be discussed individually, providing the details of how these schematics are connected to ensure a better understanding of the design. The schematic was design using the free version of EAGLE, where you can create schematics and then use them to design the printed circuit boards GERBER files to send to the printed circuit board vendors to produce your design.

Eagle is a software that focused on the design of printed circuit board. This software is known as computed aided design (CAD software). In this software a new project can be created, then there is two part for every design that is made, the schematic part and the board part. The schematic is first created, and by testing the components to ensure the final design is finalized, the board file is created, which after it is done a GERBER file is obtained. This GERBER file is sent

to the printed circuit board vendors to produce the specially designed printed circuit board.

5.8.1 MCU with RFID Reader and ZigBee Schematic

This is the main design that will provide the Smart Cornhole with the capability of detecting of the score. This designs includes three power regulators, the radio frequency identification reader, the ZigBee wireless communication module, the LEDs, and the LCD segment display. This schematic was designed based on research performed from vital references, and from rigorous testing performed using significant components.

First, the power system is made up of three different regulators. These regulators regulate the battery input voltage from 12 volts to 5 volts, 8 volts and 3.3 volts. The 5 volts output voltage will be used to power on the microcontroller unit and the RFID reader. The 3.3 volts output voltage will be used to power on the ZigBee wireless communication module. Finally, 8 volts output voltage from the 8-volt output voltage of the third regulator will be used to power on the LCD 7-segment displays, which will supply voltage to the display by wires coming out of two hole-terminals that will be soldered on the printed circuit board to the LCD 7-segment display.

The communication between the microcontroller unit with the RFID reader and the ZigBee module will be performed through the UART receiving and transmitting ports. These connections are relatively easy to understand, the receiving port from the microcontroller unit connects to the transmitting port in both the RFID reader and the ZigBee module. Moreover, the transmitting port in the microcontroller unit connects to transmitting ports in the RFID reader and the ZigBee module. These UART connections will allow the communication between the different components.

This design for the Bluetooth speaker is a subsystem from the main module inside the microcontroller. Since the whole board will be covered with foil to reduce the signal strength from the tags, the Bluetooth signal will also be affected. Therefore, the module will be placed inside the speaker's box and wired up to the main microcontroller for power purposes. This design will use the voltage out of the 3.3 volts voltage regulator in the main system, the RN-52 Bluetooth module, three push buttons, two LM386 audio amplifiers, two speakers and connections for power and programming via USB.

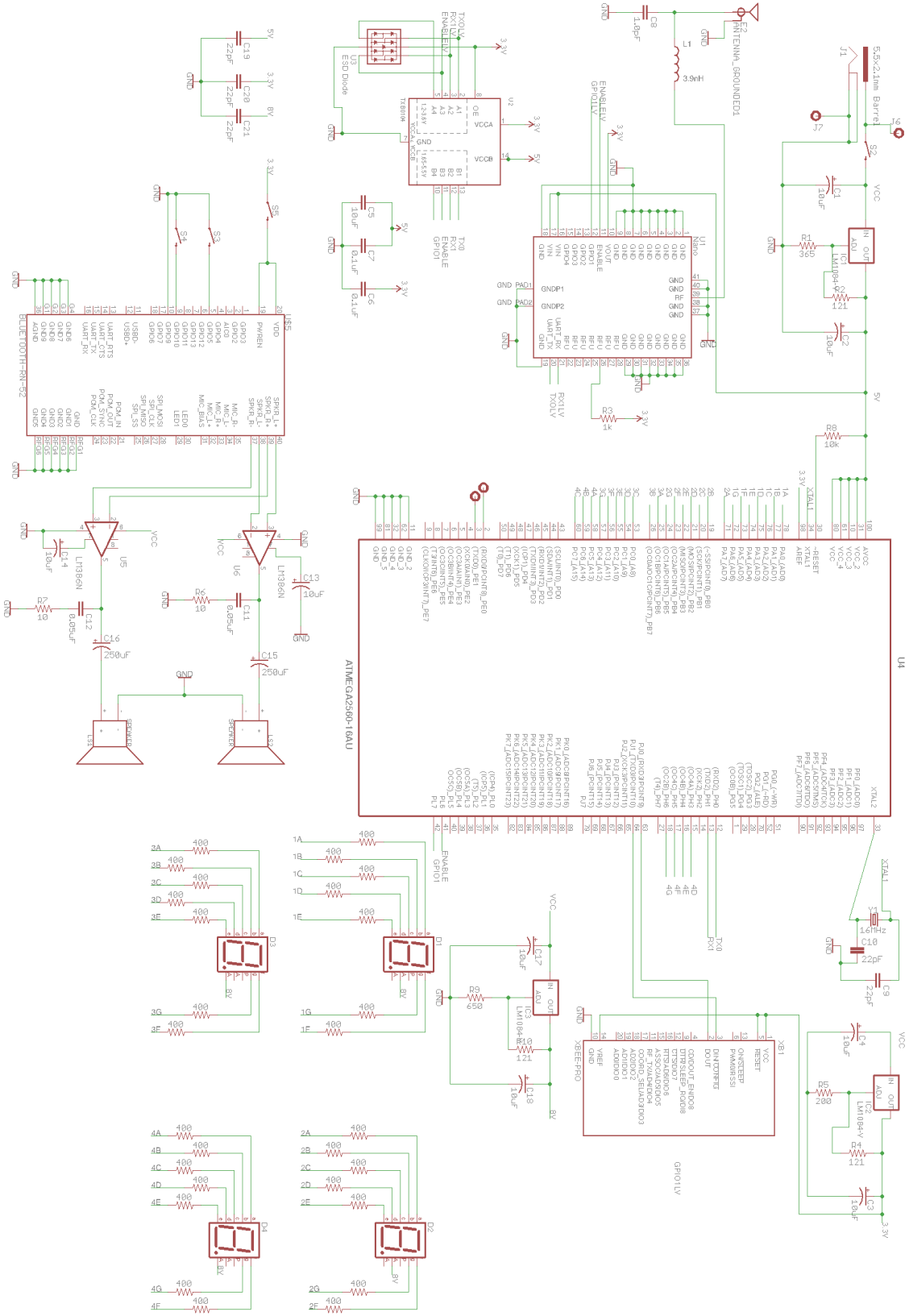

Figure 19: MCU with RFID Reader Schematic

The power system of this design will consist of one voltage regulator, this regulator will receive the same battery input as the main microcontroller, through two wires that will run to the Bluetooth module. From this input, the voltage regulator provides an output voltage of 3.3 volts. These 3.3 volts will be used to power on the Bluetooth module. In addition, implementing a push button from the 3.3 volts to the power enable pin in the Bluetooth module, this will allow the module to be power on and off.

This design also includes two speakers and two push buttons to send commands to the device connecting via Bluetooth. The two speakers implemented will be of 16 ohms, which is the max load this module internal amplifier. Since, the internal amplifier from the Bluetooth module does not contain the require power to provide a decent amount of sound of the speakers. This will have required to implement audio amplifiers between the speakers and the audio output of the Bluetooth module. The audio amplifiers chosen are two LM386N, these amplifiers require a 12 volt voltage to biased them, which will be provided from the battery. These amplifiers can be design to provide a gain from 20 to 200 depending on the speakers that are going to be drive. This LM386 is a class D amplifier, which has superior efficiency compared to class AB amplifiers.

The speakers are will not be located on the printed circuit board on this device, but rather two hole connections will be made to solder the wires going to the speakers. The speakers shown in the schematic are there for simply visual purposes. Moreover, the two push buttons will be implemented to the GPIO pins in the module, these pins will be programmed to deliver commands to the main device connected to this Bluetooth module to increase or decrease the volume of the audio played through the module. These GPIO pins can be configured to deliver more command such as play, pause, next track, previous track, etc. For our design, volume up and volume down will be enough since the other commands can be performed through the device connected to the module. Finally, there is two hole connections which will allow to connect a USB to enable programming to the Bluetooth module. These connection work as any other different data sharing connection, the receiver from the module will be connected to the transmitters from the USB, and the transmitter from the module connected to the receiver from the USB connection. This design will suit perfectly for the Bluetooth speaker the designers are trying to implement in the Smart Cornhole.

5.8.2 Module MCU with ZigBee Schematic

This is the secondary design made for the remote module to provide a wireless communication between the two microcontrollers. This design will include two voltage regulators, the main microcontroller, the ZigBee wireless communication module, two push buttons, and a USB type A female. The design was based from data researched from the different components. In addition, this is the second

design to show that wireless communication between the two microcontrollers can be achieved. Since, only one cornhole board will be produced due to economic constraints, this design will not have a custom printed circuit board, but rather use a developing board to show the communication between the two microcontrollers.

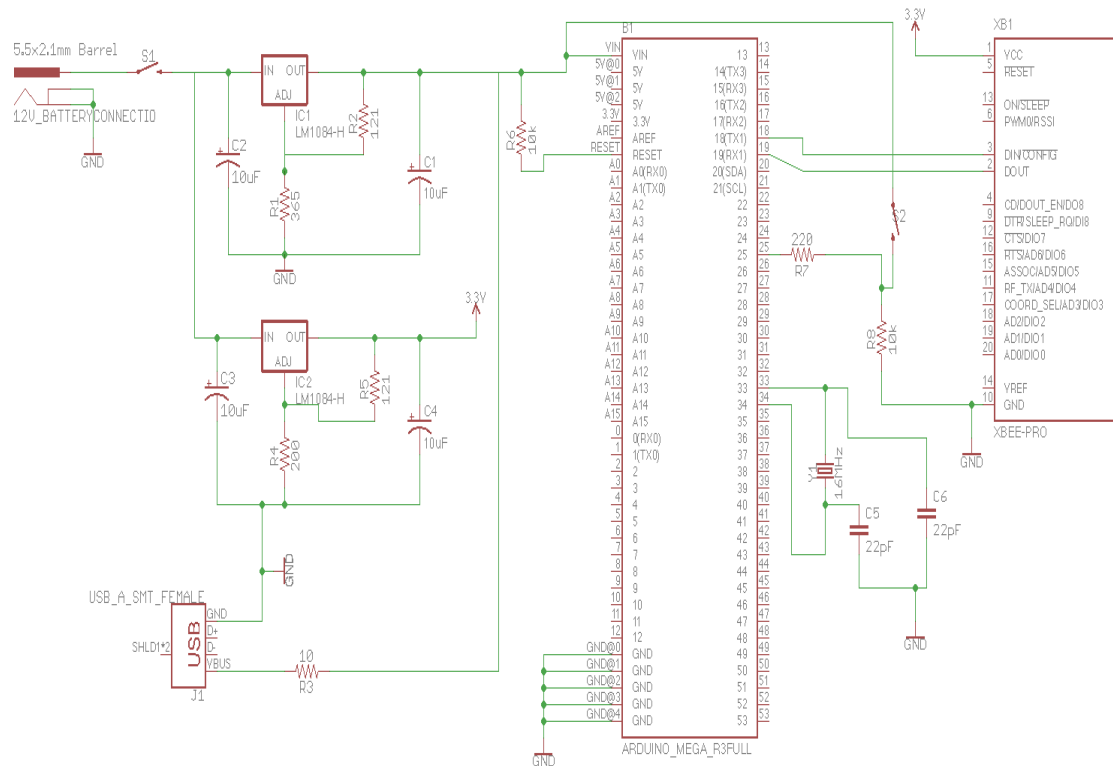

Figure 20: Module MCU with ZigBee Schematic

The power system in this schematic consists of two voltage regulators. These regulators are powered by the 12 volts input provided by the battery through a 2.1mm power jack. These regulators will then convert the input voltage into both 5 volts and 3.3 volts. The 5 volt voltage will be used to power the microcontroller unit and the USB charging port, and the 3.3 volt voltage to power on the ZigBee wireless communication module.

The communication systems will be accomplished using the ZigBee module. The microcontroller and the ZigBee wireless communication unit will send and receive data through the UART ports. The data out port in the ZigBee will be connected to the Receiving port in the micro controller, for the data out of the ZigBee to be received by the microcontroller. In the same way, the data in for the ZigBee unit will be connected to the transmitting port in the microcontroller, this will ensure the data sent from the microcontroller will be received by the ZigBee unit. The ZigBee wireless communications unit will communicate wirelessly with the other ZigBee unit in the main module inside the Smart Cornhole board.

Finally, there's a few extra features in the module. The first is the USB type A-female connection, which will be used to provide a charging port for the user. Since having Bluetooth speaker available with the design, there can be an occasion where the battery of the user's phone is at a low level. The next feature are push buttons. There are two push buttons in this schematic design. The first one will power on the module, by connecting the battery to the voltage regulator. The second push button will be used to send the signal to the main module to tell the microcontroller that it is time to calculate the score. The calculation button will be use after every turn, when all the bags are thrown.

5.9 Software Design

All the development will be done through the microcontroller and its language. The native Arduino language is easy to develop on and includes a lot of support in the form of reference able libraries for accessory hardware.

5.9.1 Design Methodology

We will be using the spiral model for development. This methodology is great because it allows us to develop on the basis of future iterations. As we develop, we can get a sense of where we are, and where we would like to go, and then develop, with that in mind. This mainly allows us to plan and develop the next iteration. Along the way, we must determine our objectives, and take into account cumulative costs; we must identify and resolve risks, and develop a prototype. After the prototype is developed, we must detail the design, code the software, integrate the code, test the code, and then implement the code. At this point, after we release a version, we can plan the next iteration.

This spiral model has six invariants that each have a key characteristic. The first is that we define artifacts concurrently, which means we need to be adaptive and adjust our objectives and constraints to please the faculty that we will be presenting the project to. The second is that we perform the following activities in every cycle: Consider the qualifications in order to please the faculty, identify if there are any possible ways to circumvent the objectives directly, identify any risks that are apparent in our approach, and get approval from the faculty for the current cycle before progressing to the next cycle.

The third invariant of the spiral model is that risk will determine the level of effort. This means that for the project activities such as: requirements analysis, design, prototyping, testing, etc. we must make a choice and determine how much effort is enough. As an example, if we were to put in more time in order to test our hardware, we may come out with a better hardware design that will look good in

the eyes of the market. The downside is that if we take too much time in order to revise and edit our hardware design, we may end up going beyond our projected timeline and in this case, we would fail the faculty review. (Normally we would fail in the eyes of the market, as there is a possibility that some other entity would push their product out first, however we are not in the actual market but rather under scrutiny by university faculty)

The fourth invariant of the spiral model is that risk will determine the degree of detail. This follows the third invariant in the risk department, but with regard to the certain degree of details supplied. An example of this would be describing something in great detail only to have shot yourself in the foot, because bringing all of the described details to life would put far too much constraint on the project; whether that be in the form of time or manpower constraints. This means not being able to deliver a detailed work because it was simply too much work.

The fifth invariant deals with milestones of the project. This is mainly organization based planning. The original spiral model did not include any information about milestones. The characteristic questions that define this invariant include: “Can we satisfy the objectives that comprise the win conditions of the faculty?”, “Is there enough definition in the current approach that satisfies the win conditions of the faculty?”, and “Is there enough planning put into place for the launch of the system to satisfy the win conditions of the faculty?”.

The final invariant of the spiral model deals with the life cycle of the system. It makes the overall system the main focus. It concerns itself with the long-term span of the life cycle. With the strict exclusion of “hazardous spiral look-alikes”, which can only spell bad news for any project life-cycle. It touches on making sure that the projects life-cycle always fails to neglect lesser needs.

We believe that with this solid design methodology plan, we can plan, design, build, and execute the software portion of this project with utmost efficiency and minimal downtime. We expect to have a wealth of revisions and iterations, but that ultimately leads to a better polished final deliverable. The spiral model is the ideal design methodology for us.

5.9.2 Development Tools

We will be using two different tools for development, the Arduino Integrated Development Environment and the ZigBee configuration utility, XCTCU.

5.9.2.1 Integrated Development Environment

An integrated development environment, or IDE, is a complete package that allows the user to develop, test, debug, and deploy software. For our Arduino

chip, we will be using the Arduino IDE. This software comes with native support for the Arduino development board that we are using, and supports the ATmega2560 Chip that we will be using on our final printed circuit board design. The development of these two is seamless and interchangeable all within the same IDE.

The computer we are using for the development of the Arduino software is already compatible since the Arduino is connected via a universal serial bus communications port. Plug and Play is native for USB devices of which the Arduino is. The Arduino software is free to use and open source. The version of Arduino that we are using at the time of this writing is the latest version of the Arduino Software, version 1.8.2.

The Arduino Software IDE allows for the integration of specific libraries that are essential to getting the auxiliary hardware components functional. The most important being the library for the M6E Nano RFID Reader. This library gives us access to important functionality so that we can integrate it into our final microcontroller code. The two most important function calls that we will be using are Read and Sleep. We will not be using the Write function at all, since we are simply reading the specific identification code for a tag and not writing any data onto the tags memory.

The Arduino Software IDE has a very unique code layout and execution. It allows the user to specify a set of initial parameters to be run at each startup. This works wonders for us because our project will need to be able to reinitialize itself following any power downs, expected or otherwise. This initial code segment falls under the Setup heading and is executed on boot every time the microcontroller receives power.

5.9.2.2 XTCU

The program we will be using to configure and setup the ZigBee/Xbee modules is called XTCU and it is Digi's in-house ZigBee configuration utility. Digi is the manufacturer of the Digi RF Module line; this includes the 1mW Series 1 Xbee module that we are using in this project. The utility is very straightforward, but it does require the use of either a Xbee explorer which is most commonly USB based, or an Arduino mated with an Xbee module. To initially setup our ZigBee network, we need to get the two modules in communication with our computer. This requires attaching the modules to our Xbee explorer board.

When the modules are first connected, we need to make sure they are at the proper settings for basic communication. This means we must have the correct communications port selected, along with a Baud Rate of "9600" bits per second, Data Bit set to "8", Parity set to "None", Stop Bits set to "1", and Flow Control set

to “Off”. What this lets the software do is to initially configure the communications port so that the computer can talk to the Xbee explorer board through USB, and therefore be able to Read and Write variables to the Xbee Module. After first connection, we need to make sure the firmware for the modules is up to date. This helps to ensure smooth operation and establishes a soft reset for both modules to clear up any issues we might encounter with old firmware that is shipped with the modules. The newest firmware revisions are available on the Digi website, our product is in the family “XB24”, and the function set is “XBEE 802.15.4” we are using firmware version “10ef” which is the latest version available on the Digi site as of this writing.

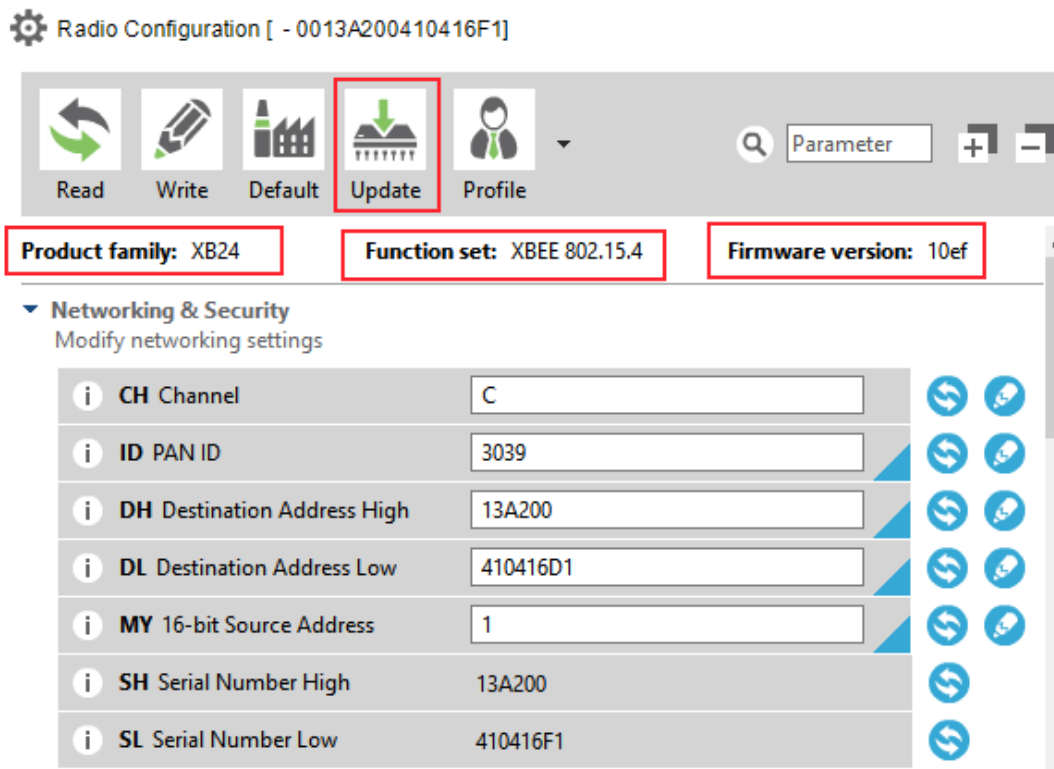

Figure 20: Firmware for XBee

5.9.3 Microcontroller Development

Our microcontroller development will be handled with the Arduino Software IDE. Since we are utilizing the spiral model for development, we will be focused on releasing iterations of our code and revising those iterations. The development on the microcontroller is the most important part of the project in terms of software. The win conditions of this development process include: Being able to read an RFID tag with the M6E Nano, being able to determine distance from signal strength, calculating the score, detecting the games win conditions, and

transferring data between the two microcontrollers via the ZigBee wireless network.

The breakdown of the code is as follows: The Microcontroller receives power and executes the bootloader which in turn runs the initial setup block of code, the ZigBee module receives power and performs its boot which handles establishing the ZigBee connection between modules (granted, the second module has power), an initial packet is sent over ZigBee and just confirms the connection is good, then the RFID reader is initialized to receive data.

There is an always-ready hard-reset function in the code that is designed to reset the game board microcontroller. This is a simple command sent from the console to the game board microcontroller through the ZigBee connection. When the game board microcontroller reads this specific string, it will then match the string to a function, that function will perform a complete reset of the entire game board system which will restart the code from the top of the setup function.

When the RFID reader is ready to read a tag, the microcontroller will wait for a signal from the console through the ZigBee connection. Upon receipt of this signal, it will execute code that will call the RFID reader Read function and that will immediately take a reading of all the RFID tags within range. The important data that is processed from this read is the TAG ID, and the Received Signal Strength Indication, or RSSI. This stream of data is then processed by the microcontroller into integer values, these values are used to then calculate the score for the completed round.

The next step for the microcontroller is to send a report of what happened through the ZigBee connection to the console microcontroller, where it will keep track of the score (a bit redundant, but it serves the purpose of locally storing the score for proof of concept and local-to-display score display).

All of this happens in an instant, and the microcontroller and RFID reader are ready to do it all again for the next round. The next round will have the software flow start from the primed RFID Reader. This will allow the microcontroller to wait for the next signal to read all the tags and perform the process all over again. Once the score calculation occurs and the game winning conditions are met, the game will complete and all functions will cease to execute except for the hard-reset function.

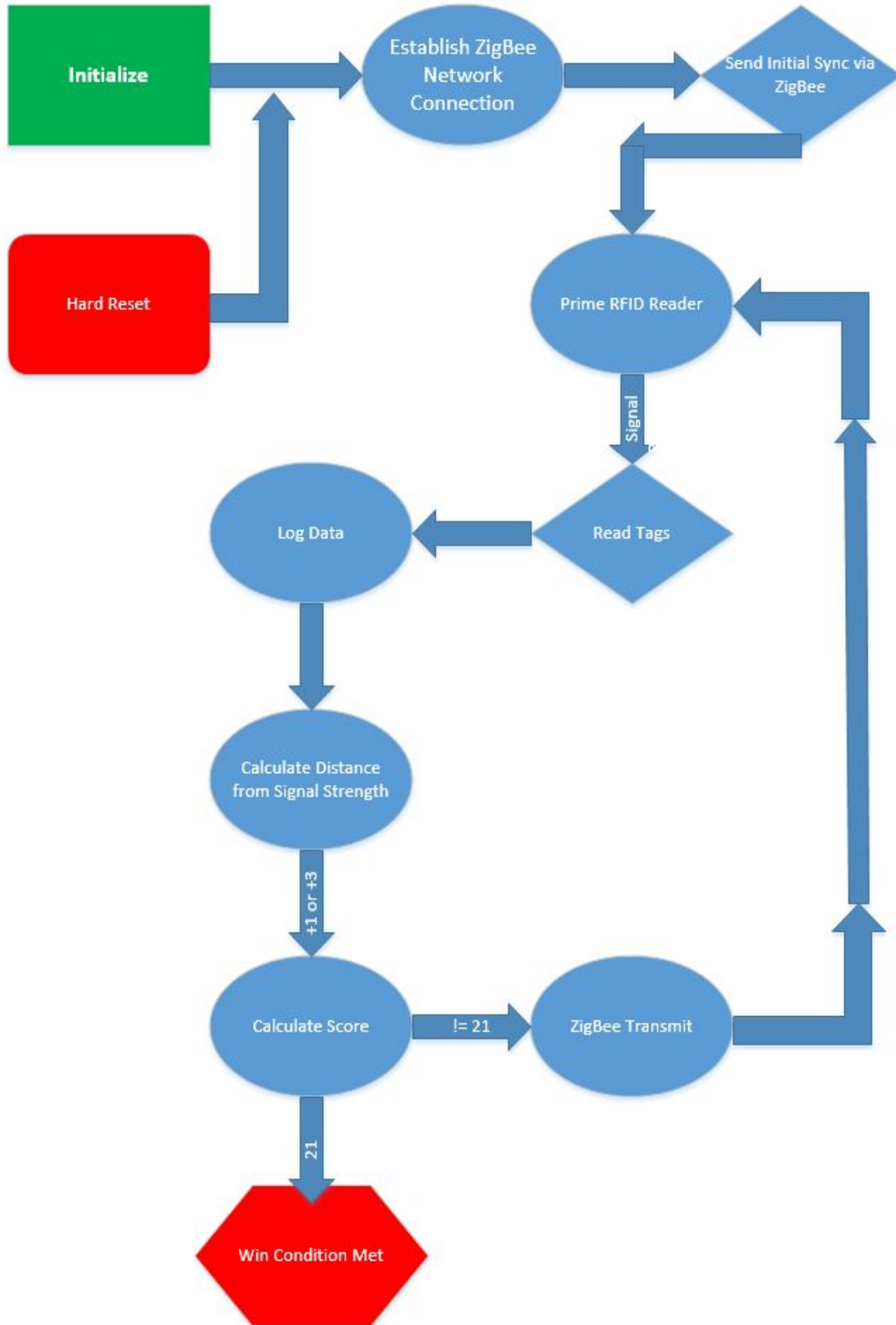

Figure 21: Main Gameboard Software Flowchart

5.9.4 RFID Development

Our RFID Reader will only be integrated in the game board system, so this section will cover the details about the development of just the RFID reader and how it integrates with the rest of the system, which is isolated to the game board microcontroller. The console microcontroller system will not have any RFID reading capabilities. The objective of the console microcontroller system is wireless proof of concept and control.

The RFID Reader functions can be accessed through an Arduino Library provided by the manufacturer of the M6E Nano Simultaneous RFID Reader. The following functions are available: “setBaudRate”, which is a function that sets the baud rate of the serial port that the M6E will be operating on; “setRegion”, this is a Federal Communications Commission regulatory setting that needs to be set to United States at all times when operating in the United States region, this is for setting the frequencies so that they are not infringing on any other frequencies; “setReadPower”, this function sets the power output to the antenna, this will determine how far the unit can read tags but at the same time increase power usage and heat dissipation; “startReading”, this function is a continuous read style call that will read until the next command is called; “stopReading”, this command follows the previous command, stops the unit from reading continuously.

The rest of the functions will not be used extensively, but are included in the library: “readTagEPC”, this function reads the EPC TAG ID and returns the value; “writeTagEPC”, this function writes data to the EPC TAG, we won’t be using this function; “readTagData”, this function reads from the tag’s integrated memory; “writeTagData”, this function writes to a tag’s integrated memory; “killTag”, this function should be used with extreme caution, it causes the tag to be killed (no longer usable within a system) if the parameters (EPC, password, and kill password), are correct.

We will be using a baud rate of 38400 bps. This is achieved by calling the setBaudRate function with the parameter of 38400. Since we are operating in the North America region, we will be putting the parameter “NA” in the setRegion function. For the final design, our read power will be set to the maximum which is 27 dBm, achieved by passing the parameter 27 through the setReadPower function.

When the microcontroller receives the specific input through ZigBee that the physical button has been pressed, the next objective of the software logic is that a function will be called which includes the startReading function call. This will get a list of tags that are in reading range, so that they can be parsed for data. With power considerations in mind, the read will only be on for less than a second. This

will keep the RFID unit in low power mode most of the time and greatly extend our battery life considering the RFID unit is the greatest power drain out of all our components.

5.9.4.1 RFID Development

Tag locations will be left to an educated guess; we know that relative signal strength indication is not an exact measurement. However, we can use this ambiguity to our advantage. Power falls over space at a rate no slower than $1/r^2$, and with that and the assumption that the RFID reader’s antenna is radiating in all directions in a uniform manner, we can get a good guess on how far away a tag is.

$$RSSI \text{ (dBm)} = -10n \log_{10} (d) + A$$

Using this equation with “d” being the distance, n being the path loss exponent which is usually between 2 and 4 (for our purposes we will use 3), and A being the RSSI at 1 meter (we will use -30 for calculation). Solving for distance will get us a table with values near what we should expect.

Table 15: Relative Signal Strength vs Distance

RSSI	Distance from Antenna (No-Foil, Meters)
-1	0.13
-10	0.43
-20	0.77
-30	1.10
-40	1.43
-50	1.77
-60	2.10
-70	2.43
-80	2.77
-90	3.10
-95	3.27
-99	3.40

5.9.5 ZigBee Network Development

To configure our two Xbee modules for communication with one another, we used the XTCU software. In this software, as said earlier, was an initial configuration for

communication between the Computer and the Xbee modules. Now we need to configure each Module with certain parameters such that the Modules can communicate with one another on their own without the help of the computer. This is done via a set of variables that are written into the module.

The first parameter we need to deal with is the Channel; this variable needs to be set to a letter of the alphabet, which needs to be the same across both modules. The default setting for this variable is Channel “C” and that will work just fine for our application since we are using just two Modules and there does not need to be an intricate network channel setup.

The second variable we need to setup and push to the modules is the PAN ID, or Personal Area Network ID. This variable is setup in hexadecimal and refers to just a number that the modules will be referring to when they first initialize and have to figure out what Personal Area Network they will be deployed in. For both modules, this number will be the same since we are just using two modules. In this case, we will be setting both modules to hexadecimal “3039” which is just “12345” in decimal.

The third variable is the Destination Address High, or DH. This value must be set to the Serial Number High, or SH, of the opposite module. So, for module 1, we are setting the DH to “13A200”. For module 2, we are also setting the DH to 13A200, because it just so happens that the SH for both modules is the same. We are able to leave both DH values at “13A200”, which makes it one less step for configuration.

The fourth variable is the Destination Address Low, or DL. This value must be set to the Serial Number Low, or SL, of the opposite module. So, for module 1, we are setting the DL to “410416D1”, which is the SL of module 2. For module 2, however, we will be setting the DL to “410416F1”, which corresponds to the SL of module 1. Notice how these DL values are different, these are used as the unique addresses of communication.

The final value that we must set before we can really get these modules to communicate with one another, is called the 16-bit Source Address. This is also referred to as the MY Address. This is a value that we can set that determines which module is the communicator and which is the communicated. For our purposes, we will be setting both of the values to “0” or “1”, both of which can serve our needs. When both modules have their MY Address set to the same values, they will both receive the same information from any other Xbee modules in range, this will have no negative effects considering we are using just two modules. Even if we were to set one of the modules to “1” and the other to “0”, it would not matter since they are both in communication.

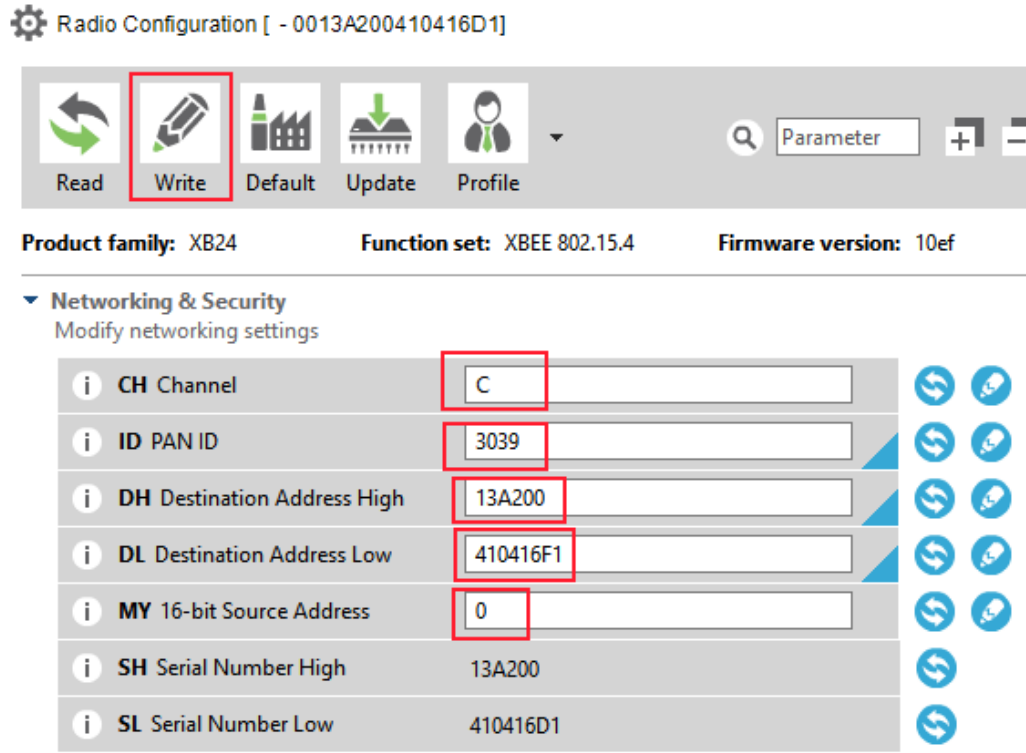

Figure 22: Xbee module written values

With all of these values set, we can write the values using the AT Write command in the XTCU software, this will write the variables to the memory of the modules. With the values written to memory, they will be remembered across power cycles. Configuration of Xbee modules is a one time setup and will not need to be messed with again for the duration of our project unless we want to change the network configuration because of unintended interference, or the addition of new Xbee modules.

5.9.6 Console Development

The console has its own microcontroller and software flow, so it has its own separate development ideology. The initial microcontroller setup is similar, but lacks the RFID reader section.

The bootup sequence remains largely the same, with the microcontroller receiving power, then executing its setup block of code. The Xbee module receives power and initializes a connection with the second paired Xbee module. A test packet is sent to confirm the connection between the two modules. Then, instead of initializing the RFID reader, we get the microcontroller ready to receive data from the Xbee module. Once data is received, the score is updated locally and is ready to be displayed.

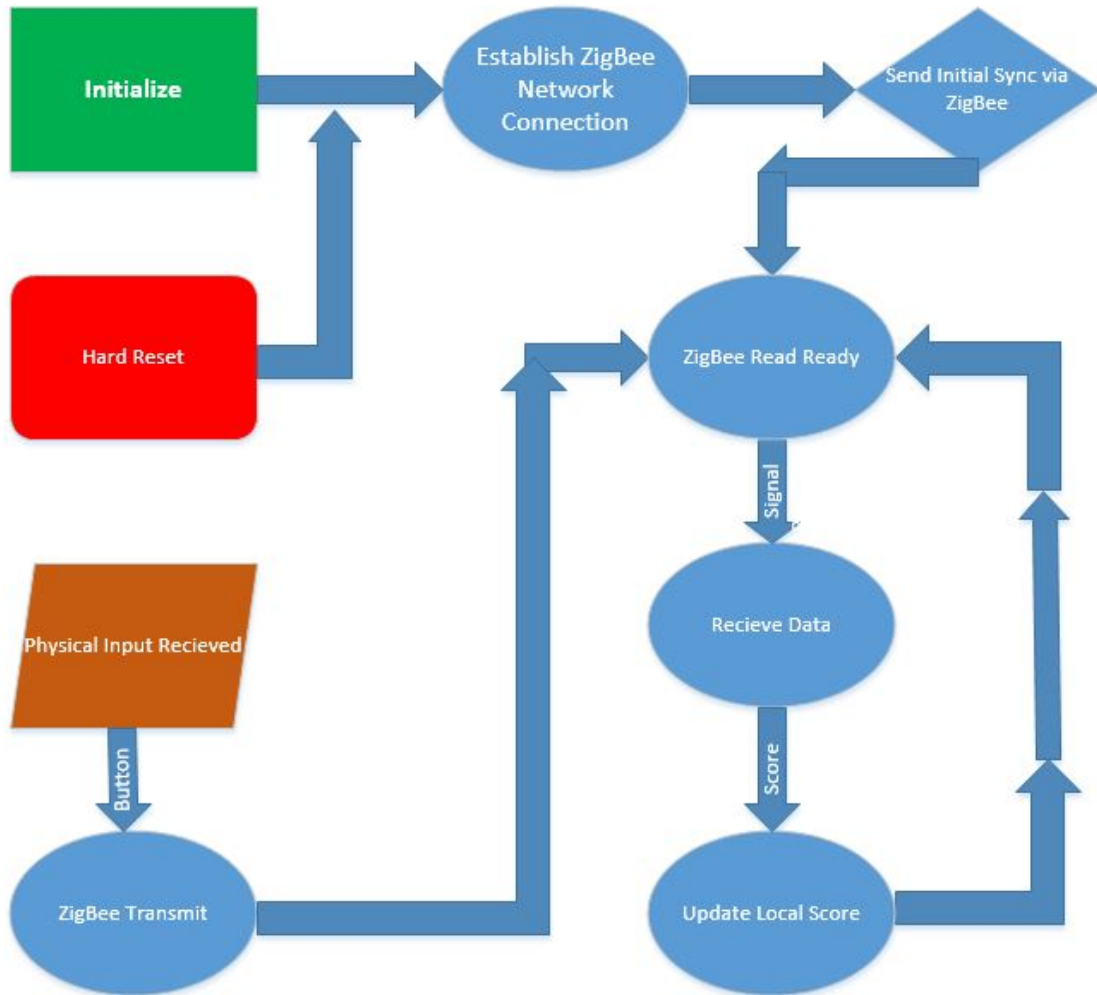

Figure 23: Console Software Flowchart

The console will have a physical push button switch; this switch will be action timed and will do different things depending on the length it is pressed.

Table 16: Console Switch Actions

Switch Time Pressed vs Action	
Under 1000ms	Next Round
Between 1000ms and 2999ms	Do Nothing
Between 3000ms and 10000ms	Hard Reset
Over 10000ms	Do Nothing

5.9.7 Display Development

The 7 segment displays that we have, each have 10 pins that need to be PWM controlled by the microcontroller. Each pin has its own role in the IC digital system, and with a little help of state tables and the IC diagram, we programmed a function in our Arduino code that passes parameters to determine what digit to display.

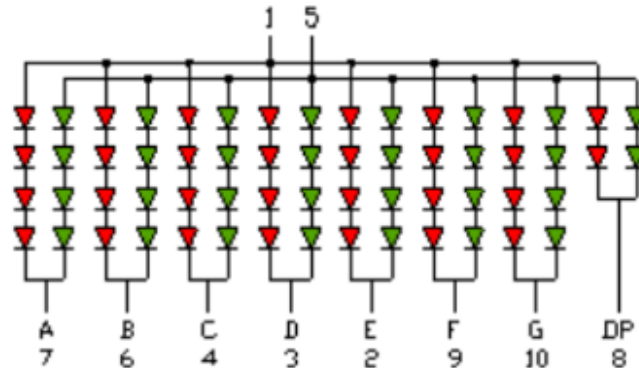

Figure 24: Pin setup for 7-segment displays

5.9.8 Display Development

The Console microcontroller will handle the display of numbers on each of our seven segment displays. The display we chose to use is Common Anode design, which means each segment is active low. We will be using 4 decoder modules in order to display the numbers that we want without using too many pins. The input for the decoder will be in Binary Coded Decimal, and the decoder will do its job and set the specific pins to low.

While the table below shows us, which segments must be active low in order to display which number, the table below will tell us what specifically we need to tell the decoder in order to get the right combination of active low signals. This is essentially hexadecimal to decimal conversion; the decoder chip does the rest.

Table 17: 7-Segment Decoder Decoded

Number Displayed	Segments						
	a	b	c	d	e	f	g
0	x	x	x	x	x	x	
1		x	x				
2	x	x		x	x		x
3	x	x	x	x			x
4		x	x			x	x
5	x		x	x		x	x
6	x		x	x	x	x	x
7	x	x	x				
8	x	x	x	x	x	x	x
9	x	x	x	x		x	x

Table 18: 7-Segment Decoder Input Truth Table

Decimal	Binary "Hexadecimal" Pattern				Binary Coded Decimal
	8	4	2	1	
0	0	0	0	0	0
1	0	0	0	1	1
2	0	0	1	0	2
3	0	0	1	1	3
4	0	1	0	0	4
5	0	1	0	1	5
6	0	1	1	0	6
7	0	1	1	1	7
8	1	0	0	0	8
9	1	0	0	1	9
10	1	0	1	0	Not Used

When the decoder sees the active high or low inputs on the 4 pins, it will then take that combination and translate it into which of the 7 segments it should activate. For example, to light up the number "5" on a seven segment display through the decoder, we instead activate pins 1 and 3 on the decoder, which will tell it to set active low on segments a,c,d,f, and g. Having a pin input to the decoder that results in a number higher than 9 will have no effect.

5.10 Summary of Design

In summary, we will be using the ATmega640V-2560 microcontrollers to be the brains of this project. These microcontrollers are a good fit because they have all the necessities we require, including but not limited to, good input voltage range, a lot of GPIO pins, fast clock speed, low power consumption, and native libraries for development. Our power will come from a 12-volt battery pack that has 3500 mAh of capacity. This choice gives us a good maximum potential runtime so the game can be played longer. We will be implementing a Bluetooth speaker in the design, which is for the players to use and listen to music whilst playing the game. The speaker will be configured using a RN-52 Bluetooth module and two speakers in stereo configuration.

For wireless communication between the two microcontrollers, we have chosen to implement ZigBee in our design in the form of two Xbee 1 mW Series 1 modules. These modules allow our microcontrollers to perform as if they were connected with a wired serial connection, across a range of up to 300 ft. in clear line of sight. The star component of our system is the M6E Nano Simultaneous RFID Reader, this component in the bread and butter of our setup. This RFID reader allows us to accurately read RFID tags that are located in our beanbags. The output will also let us determine the location of these bags for accurate scoring. The read strength of the tags, which is the method we are using to determine the location of the bags, is going to be cleverly modified by layers of aluminum foil that will be strategically placed around the game board.

We will be using seven segment displays so the players and spectators can view the score in real-time. We will also have LED strips in order to improve visibility during low light situations and for aesthetics.

The entire system will include a Console, this is a standalone structure that has its own microcontroller system and also includes a physical switch. The purpose of this Console is for proof of concept that we can do the wireless communication and be able to implement this into an actual two-game-board setup. The console will be using the same battery type as the main game board system, a 12-volt 3500 mAh variant. This console will also have a USB port for charging devices such as an off-the-shelf Bluetooth speaker.

The software of the system will be designed with the spiral model of software design methodology in mind. This focuses on multiple iterations and revisions to each release. We will be using the Arduino Software IDE to develop all of our code. We will also be utilizing the various software libraries that are free to use and match with our hardware. Configuration of the Xbee modules will take place in the XTCU software which is provided for free by the manufacturer, Digi.

The overall software layout will include multiple functions that each have a specific but important role when tasked with integrating all of our hardware together. These functions include, at minimum, setup and loop. Those two functions are the most important to any Arduino code. We will have a function that reads the tags, one that sorts the tags that are read, one that determines whether a specific bag is in-play for the round, one that calculates the score, and one that transmits the score over ZigBee.

6.0 Subsystems Testing

To implement a successful project, all the selected parts must be tested thoroughly. This could be accomplished by testing every single part from resistors up to microprocessors. It is vital that every part is working to their expected standards. If any failure of a part should be addressed before the integration of the whole system. After the successful testing of each part, the whole system will be tested. This will lead us to our final product. The results obtained from the testing will be used to connect system together and how the power will be distributed. The test and results of the testing will be discussed in the following section.

6.1 Arduino MEGA 2560 Testing

This is a powerful microcontroller with 54 digital I/O pins, of which 16 are analog inputs and 15 have width pulse modulation capability. It has 256KB of flash memory. The crystal clock speed of 16Mhz. The operating voltage is 5 volts.

Objective: The goal of testing this microcontroller is to ensure that it is functioning properly and safe for use. This test is necessary because it will be used to program XBee's wireless module and other subsystems. The test will consist of, programming Arduino MEGA 2560 with a blinking LED at pin13.

Environment: Most of the subsystem testing were performed at UCF's Senior Design Laboratory located in Engineering 1, Room 456. The laboratory equipment used to perform this test includes:

- Arduino MEGA 2560 Microcontroller
- Personal Computer
- USB cable A to B 2.0
- LED Light
- ARDUINO Software (IDE) 1.8.2

Procedure: Following steps were followed to test this hardware:

1. We connected Arduino mega 2560 with USB cable A to B to our personal computer, while ensuring all the connections are connected to the correct connector/terminal.
2. We checked the green light is shown on the board is ON, which means it is successfully powered and connected.
3. We Downloaded Arduino software which is available online for free to install and use (<https://www.arduino.cc/en/Main/Software>). After downloading the program, we installed program named, aurdino.exe.

4. We went to the tool bar clicked on File> Examples> 01. Basics> Blink. These program is pre-written and available for free to test and learn about microcontroller.
5. Once the program was downloaded with file name blink, it was uploaded to the Arduino board by clicking on the upload bottom (->).
6. We also plugged in a LED light on with positive long leg in pin 13 and negative leg to ground pin.
7. Finally, on the pin 13 your LED will be blinking.

Conclusion: The successful testing of the blink test proves that our Arduino is working well and ready to use.

6.2 XBee 1mW Wire Antenna Testing

This module is little but has an astonishing strength of sending RF signals back and forth at a great distance. It has a range of 300ft outdoor and 100ft range indoor. It has a data rate of 250,000 bps. It has a supply voltage of 2.8-3.4v. Since, the size of Xbee is tiny then it requires an extra attachment to sit-in on top of the Arduino or the breadboard. There are many ways to test and configure Xbee.

Objective: The goal of testing this hardware is to configure and program them to communicate with each other wirelessly. After that we will program the Arduino so the computer can understand the code and turn on a LED. The test will be proved by turning on LED with command 1 ON and command 0 OFF.

Equipment: The apparatus used to configure and test this hardware are:

- Arduino MEGA 2560 Microcontroller
- XBee 1mW Wire Antenna
- XBee Explorer USB
- Xbee Shield Module for Arduino
- Personal Computer
- USB cable A to B 2.0
- LED Light

Procedure: Due to the long procedure and multiple, complicated steps that are required to be followed, a summary will be listed below into two different parts. The first part will describe programing/configuring of XBee and second programing of Arduino.

To program Xbee, it needs to be configured with a x-ctu software, which was downloaded from digi.com to the personal computer. After the installation of program, we connected USB cable 2.0 to Xbee Explorer USB which sits on Xbee 1mW wire antenna module. X-ctu program detected the USB connection of our Xbee. We ran several test queries before modifying the configuration. We

updated our Xbee to the newest firmware. We made necessary changes to the settings and configuration as required for successful communication between the two Xbee's. It took several minutes to upload the newest settings. After the successful implementation of program to first Xbee it was disconnected. The second was connected the same way and same steps were followed. Both were successfully configured and programmed.

To program Arduino, the same 1-3 steps were followed which is listed in testing of Arduino mega 2560. The set up for this procedure Arduino was included, where Xbee Explorer USB and Xbee 1mW wire antenna module both were sited on Arduino and connected by USB A wire. The new file was created for new program and the new program was written. The written program was uploaded to Arduino. After the successful implementation of the program necessary test with 0 and 1 were connected. The table 15 below represents the successful implementations of Xbee test.

Table 19: Xbee test

Command	LED ON or OFF
1	ON
0	OFF
1	ON
1	ON
0	OFF

Conclusion: The successful testing of turning ON and OFF a LED light proves that our microcontroller will be able to transmit the scores to both display screen wirelessly.

6.3 Simultaneous RFID Reader - M6E Nano

This RFID reader is the most important and the most expensive component of our project. It has capability up to 150 tags/sec to read at 96-bit EPC. It boots up in less than 30 msec. The voltage consumption 1.5-5.5v depending active and inactive protocol.

Objective: The goal of testing this hardware is to verify the capability of reading multiple 860-920MHz UHF RFID tags at the same time with different distances.

Equipment: The apparatus used to configure and test this hardware are:

- M6E Nano
- RFID Tags
- Personal Computer
- Universal Reader Assistant software

- USB Serial Bridge

Procedure: Testing procedure was quite simple and straight forward. We connected M6E Nano to computer with the help of microcontroller. For a quick and effective test, Universal Reader Assistant software was installed on personal computer from the thingmagic.com which was available for free. We made necessary changes to the settings and configuration as required for successful detection of tags. We tested out several different tags at different distances, which was detected by the software. The read power of the RFID reader was set to +27 dBm which is the maximum allowed setting for the reader. The table below represents the successful implementation of the test.

Table 20: RFID Signal Strength Test

Distance of Tag from Reader	Signal Strength
6 inches	-30 dBm
12 inches	-39 dBm
18 inches	-43 dBm
24 inches	-47 dBm
30 inches	-52 dBm
36 inches	-58 dBm
42 inches	-65 dBm
48 inches	-73 dBm
54 inches	-82 dBm
60 inches	-97 dBm
66 inches +	No detection

Conclusion: The successful testing of reading multiple 860-920MHz UHF RFID tags at the same time with different distances will bring us one step closer to the totaling scores of both teams.

6.3.2 Simultaneous RFID Reader - M6E Nano With Different Aluminum Layers

Objective: The goal of this test this to verify the capability of reading multiple 860-920MHz UHF RFID tags at the same time with different distances and different Aluminum layer.

Equipment: used to configure and test this hardware is as follows.

- M6E Nano
- RFID Tags
- Personal Computer

- Universal Reader Assistant software
- USB Serial Bridge
- Aluminum

Procedure: We followed the same procedure steps as 7.3.1 procedure to achieve the successful results. The table 16 below will represent the results of test.

Table 21: 16 M6E Aluminum Layers Test

Layers of Aluminum foil	Distance apart	Signal Strength
0	1ft	-37.9 dBm
0	1ft	-38 dBm
1	1ft	-67.9 dBm
1	1ft	-67.7 dBm
2	1ft	-95 dBm
2	1ft	-95.1 dbm
3	1ft	No detection
3	1ft	No detection
4	1ft	No detection
4	1ft	No detection

Conclusion: The successful testing to verify the capability of not to read multiple 860-920MHz UHF RFID tags at the same time with different distances will help us not to consider the bags for totaling the scores that have not landed in a hole or either on a board.

6.4 LM1084 Voltage Regulator Testing

The goal of testing LM1084 voltage regulator is to maintain the constant DC to DC voltage to the different subsystem of design. It requires two resistors to set the output voltage. Testing this hardware was quite simple and straight forward. We performed the test on breadboard at UCF senior design lab. Since, it requires two resistors, the appropriate values for 3.0v, 3.3v, and 5v were calculated. After the calculations, the circuit was designed on Mutlism and breadboard for the test. Since, we needed three different output voltage the test and calculations were performed three separate times with the same steps. The data was recorded and was up to the standards. The table 16, 17, and 18 below represents the successful implementation of the voltage regulator test.

Table 22: Voltage regulator RFID and microcontroller test

Battery Vin	Regulator Vout
8v	4.95v
10v	4.99v
12v	5.01v
15v	5.03v
17v	5.03v
20v	5.03v
23v	5.04v
25v	5.03v

Table 23: Voltage Regulator Xbee and Bluetooth test

Battery Vin	Regulator Vout
8v	3.26v
10v	3.28v
12v	3.31v
15v	3.32v
17v	3.32v
20v	3.32v
23v	3.31v
25v	3.32v

Table 24: Voltage Regulator Seven Segment display test

Battery Vin	Regulator Vout
8v	8.001v
10v	8.001v
12v	8.000v
15v	8.002v
17v	8.001v
20v	8.003v
23v	8.001v
25v	8.002v

6.5 Seven segment display, Tri-Color Testing

The goal of testing seven segment LED display is check that all seven-digital segment are functioning properly. In addition, it will be able to be configured with microcontroller. The reason it is called seven segment because there are seven LEDs bundled together to form a pattern of different numbers. To test this display, we simply hooked up our Arduino Mega 2560 with help of USB to our personal

computer. After Arduino was powered, we connected a wire to pin 13 and performed test on each LED segment individually to check if their function is up to the standards. After successful implementation of check, we went step further and programmed the led lights to go up to 21 which is the score required to win the cornhole. The new file was created and necessary program was written and uploaded to Arduino. The results were as expected and all the numbers were displayed correctly on the LED segment. The successful testing of this hardware proves that our score will be displayed perfectly on the display screen. The figure below represents the successful implementation.

6.6 Decoder Testing

The objective of testing the decoder is to make sure that the general inputs of the decoder on each of the 4 pins matches the desired output of the decoder across 7 pins. When we have a binary coded decimal of “0001”, which is simply “1” in decimal, we want to make sure that the decoder will accurately send the correct active low signals to the correct pins in order to activate a “1” on the seven segment display. We also want to be thorough in our testing so nothing was spared.

Table 25: Decoder Testing 4 Input 7 Output

Specified BCD Input Pins 1,2,3,4	Decoder Active Low (Ground) Output Sections						
	a	b	c	d	e	f	g
0000	Yes	Yes	Yes	Yes	Yes	Yes	No
0001	No	Yes	Yes	No	No	No	No
0010	Yes	Yes	No	Yes	Yes	No	Yes
0011	Yes	Yes	Yes	Yes	No	No	Yes
0100	No	Yes	Yes	No	No	Yes	Yes
0101	Yes	No	Yes	Yes	No	Yes	Yes
0110	Yes	No	Yes	Yes	Yes	Yes	Yes
0111	Yes	Yes	Yes	No	No	No	No
1000	Yes	Yes	Yes	Yes	Yes	Yes	Yes
1001	Yes	Yes	Yes	Yes	No	Yes	Yes

As we applied an active high signal to each one of the input pins on the decoder, we were provided active lows on the output pins that usually would connect to the seven-segment display. These are accurate in what we had expected, and will be implemented in the development of the code we will be using for the microcontroller.

6.6 RN-52 Bluetooth Testing

The RN-52 Audio Bluetooth is an awesome audio module from Roving Networks. It is designed on PCB and easy to use. It allows user to send stereo audio via wireless Bluetooth connection. It is easy to configure. It can function on standalone method or with a microcontroller to create an ultimate wireless audio experience. It is a Bluetooth v3.0 module. The supply voltage is 3.0v-3.6v.

Objective: The goal of testing this hardware is to configure and program the RN-52 module so it can be connected wirelessly via Bluetooth to a mobile device.

Equipment: used to configure and test this hardware is as follows.

- RN-52 Bluetooth
- FTDI Basic Breakout
- 2 Speakers
- Personal computer
- Breadboard and jumper cables
- Voltage regulator
- Mobile device

Procedure: Due to long procedure and multiple complicated steps are required to be followed, a summary is provided instead of long steps. Before the configuration of this module, hardware needs to be set up on breadboard. We used necessary wires and breadboard to set up the module. Since, it only takes a 3.3v to power up a voltage regulator was used with necessary resistors. We than connected GND to GND, TXO to UART_RX, and RXI to UART_TX. Those are the only connections needed to talk to the module. That was main set up for configuration of module. We also connected the speakers with wireless to appropriate slot. We supplied power to the breadboard to turn on the RN-52. The LEDs on the RN-52 both stayed solid and after few seconds the second one started blinking. Our device was read to make connection. We updated the necessary settings and updates as instructed on sparkfun.com. The steps given were little complicated and tedious to follow but we achieved it. Finally, our Bluetooth was ready to be connected wirelessly via mobile device. At last, we connected RN-52 to our mobile device and tested out few songs. We also tested volume control. Furthermore, we tried an incoming call while audio was streaming from smart phone, the speaker instantly stopped the music and begin to ring until the call was answered or rejected.

Conclusion: The successful testing of RN-52 module brings us closer to an entertainment side of our project. Later, it will be integrated and tested with the whole system.

6.7 LED- Strip Testing

The goal of testing LED-strip display is check that all LED segments are functioning properly. In addition, it will be configured with microcontroller and battery to ensure LEDs can turn all the way off and on when power is supplied. To test this segment, we simply hooked the positive and negative wires of LEDs with voltage regulator in breadboard. The successful testing of this hardware proves that our LEDs are functional and will enhance the show of our project.

7.0 Project Prototype and Coding

The following section will have detail information about implementing the successful integration of all the subsystems into one final system. After the successful testing of all the subsystems it is important to put the system together and check if all the subsystems are functioning together as to their expected standards. Integration of each system together is important, since it will give us the result to final step of the project which is PCB design. Integration of the systems will be done on the different breadboards and then It will be connected to together check for the results.

7.1 Prototype Testing

In this procedure, necessary chips and components were broken out from microcontrollers and were customized and tested onto different breadboards. It was accomplished by ordering necessary parts from selected microcontrollers. In addition to that, a lot of wires and different type of resistors and capacitors was used because each subsystem has different power requirements.

The goal of testing all components together is check their functions and results produces as a one whole system. The equipment required are as follows.

Equipment:

- ATMEGA2560 Chip
- TQFP-100 PA0109-ND
- Soldering machine
- M6E Nano
- RFID Tags
- USB Serial Bridge
- RN-52 Bluetooth
- 2 Speakers
- Personal computer
- Breadboard and jumper cables
- Voltage regulator
- Mobile device
- Battery 12v
- Resistors
- Capacitors

The implementation of the testing was long and challenging, but surely was accomplished. We divided different subsystem into different breadboards. First breadboard strictly focused on the testing ATMEGA 2560 chip. We ordered the

chip and customized breakout board from the digikey.com. After, arrival of the necessary components the chip needed to be soldered on the TQFP-100 PA0109-ND board. To solder the chip was one of the most complicated procedure of all, because of its tiny size and detailed tailoring. Since the soldering that chip required high level of experience and skills, we received a professional help. Finally, chip was soldered on and was ready to be plugged in the breadboard for the testing. The necessary connection was made to connect the RFID and LCD segment display. After the completion of the first breadboard set up, we moved on to the second breadboard setup.

Second breadboard was RFID M60E. This component required soldering of some pins, so it can be plugged in the breadboard. Once all the pins were soldered into the M60E, we assembled it in on breadboard. We connected it with voltage regulator since it requires 5V to power on. We connected the necessary wires to the pins of the AT mega 2560 chip to program it in order to the detect the scores from RFID tags. After that the completion of the second breadboard set up, we moved on the third breadboard setup.

Third breadboard was Bluetooth module RN-52. This component required soldering as well such as speakers, wires, and pins on RN-52 module. Once all the pins were soldered into the RN-52, we assembled it in on the breadboard. We connected it with voltage regulator since it requires 3.3V to power on. In addition, an audio op-amp was added to the testing, which enhanced the output of volume of the speakers. After that the completion of the third breadboard set up, we moved on the fourth breadboard setup.

Fourth Bread was seven segment LED display, since we run out of the breadboards we connected it with two smaller breadboards. We assembled it in on the breadboard with resistors and voltage regulator. Due to the wrong data sheet, we were not able to accomplish to turn on the led segment. After few phone calls to the company that we ordered this part from, we had right voltage and information to connect LED display screen. It required 8v to turn on the red segment. Positive terminal should be connected to both 1 and 5 pin for the red color LED display. After that the completion of the fourth breadboard set up, we moved on the final steps.

The final steps of the procedure required it to connected from one 12V battery power source and it to be programmed. Since, the different subsystems required different output voltage, we used three different voltage regulators to controller three different output voltage which was 3.3V, 5.0V, and 8.0V. We also added two switches in between the setup that turned on the power for RFID and Bluetooth module. After the whole set up, we checked the schematics and verified each connection of wires was properly connected and ready to be powered on and function. Once, the power set up was complete we moved on to the programming the chip. The programming the chip required heavy programming

and complicated set up to it. After few researches and information required of pin layout of mega250, the new file was created for new program and the necessary new program was written to test the integrated system. Than the program was uploaded to the chip.

Finally, the power was supplied from the battery to all the components. We turned on all the switches to power on the different subsystems. Power was successfully delivered to all the subsystem without any errors. The RFID module was turned on and ready to function. The Bluetooth module was ON ready to connect to the mobile device with specific name assigned which was Smart Cornhole. Than we were the ready to the test the RFID tags to detect the score and display it on the LED segment. First few tries we were unsuccessful due to the programming error. We than checked for the errors and rewrote the program and then connected it to the microcontroller for some pretest instead of the testing it with chip and whole prototype. The new program was successfully implemented and could detect the score. We reconnected the few connections and uploaded the new program to the mega2560 chip.

We supplied the power again to all the segments and it was successfully turned on. We brought the RFID tags close to second subsystem and it successfully detected the RFID tag. The score and displayed it on the LED segment within few milliseconds. We conducted the few tests with different RFID tags. Furthermore, we also used different distances with the RFID tags just to make sure that all the subsystems are functioning according to their standards.

In conclusion, testing all components together and checking the results produces as a one whole system brings us close to our final design. In addition, successful testing brought us to next major step is PCB design. PCB design will be implemented in next class with the final presentation of our working Smart cornhole system.

The successful implementation of the whole prototype with all the necessary connections are displayed in the picture below.

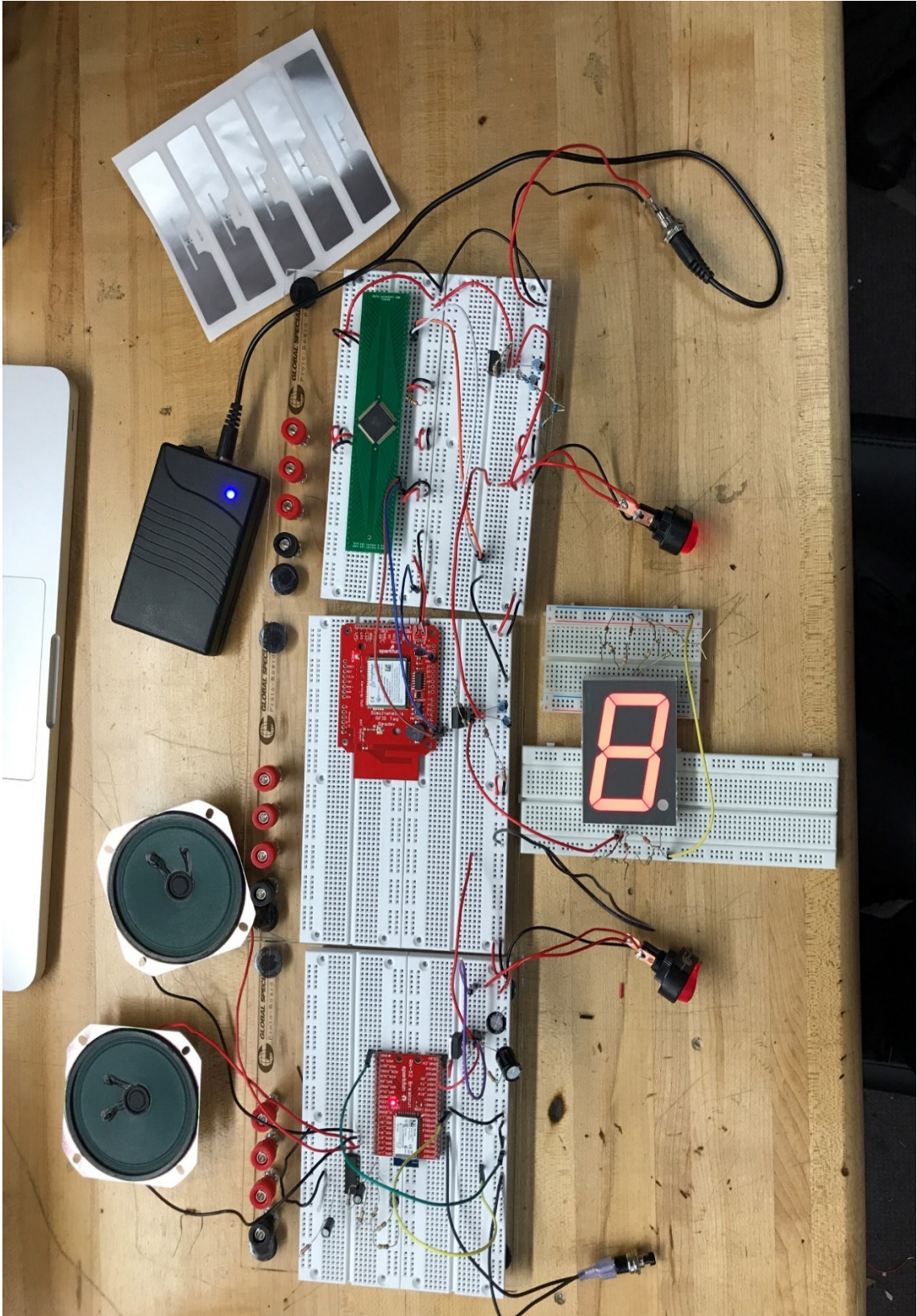

Figure 25: Breadboard Prototype testing

7.2 PCB Design Prototypes

Finishing the design of this project, based on the results from testing perform, the design must be implemented into a printed circuit board to provide a superior project that is professionally done. Using the EAGLE software to turn the schematic into a printed circuit board design. The components were place strategically to reduce the distance of electrical traces to the least possible distance.

Since the foil to reduce the signal strength for the RFID tags will be surrounded the whole cornhole board, this will have a great impact to the Bluetooth module, which is why it was decided to split the printed circuit board into two, the Bluetooth module and the main microcontroller with RFID. The Bluetooth module will be place outside the foil to ensure that connectivity and wireless range is at its maximum performance. The following figure shows the prototype printed circuit board design for the Bluetooth module.

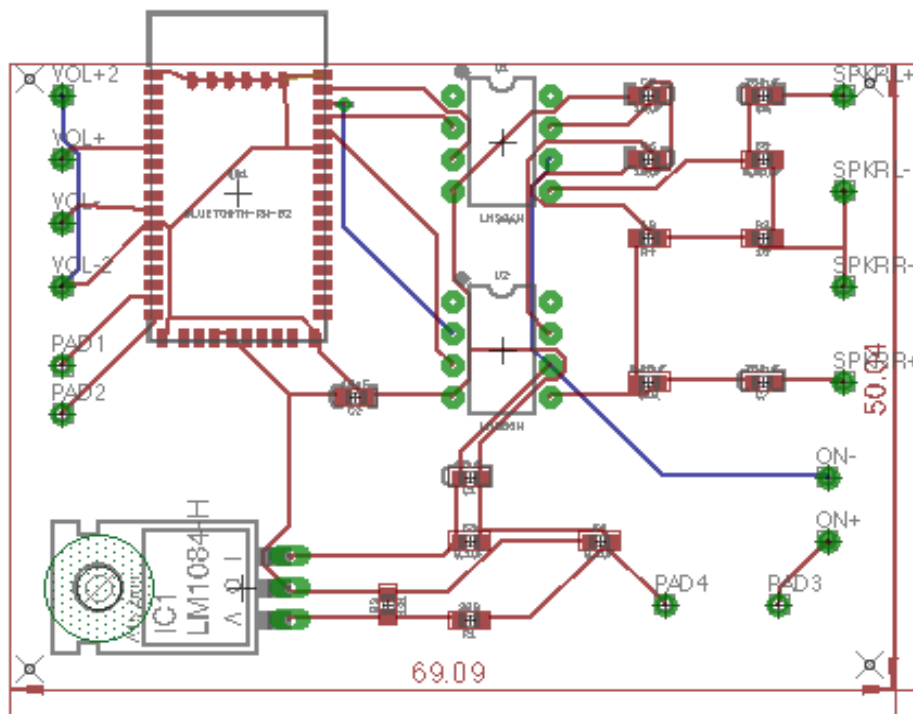

Figure 26: Bluetooth Module Prototype PCB

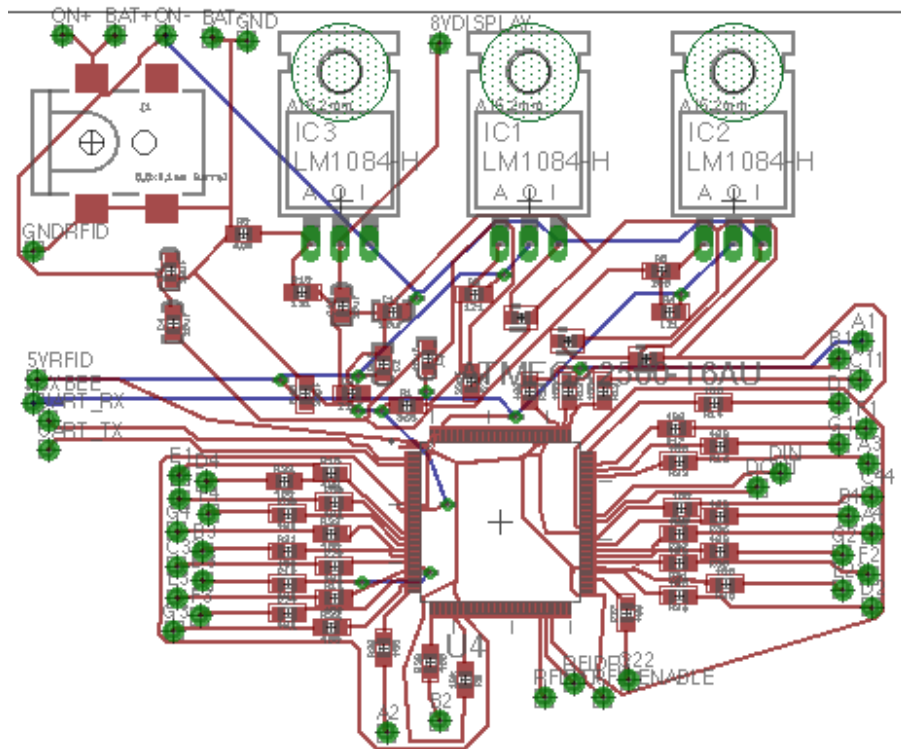

Figure 27: Game board Prototype PCB

7.3 Final Coding Plan

The code, written in the Arduino Software IDE, will be split among several functions. Each function has a distinct purpose in the overall flow of the code. The general layout of Arduino code:

- Header, with includes and the initial comments
- Setup, with initial values
- Loop, with continuous execution
- Sub-functions, each with their own specific role

7.3.1 Initial Heading

In this section of the code, there will be the inclusion of the library required to read and write to the serial. The communication is done via Universal Asynchronous Receiver/Transmitter, or UART. The file referenced is “SoftwareSerial.h” and it includes several functions for reading, writing, and printing; which will help us later on, when we are interfacing with the Xbee and RFID modules. The SoftwareSerial is first initialized, that creates an instance of the Serial we will be using throughout the program. Then we must reference the RFID Reader library, “UHF_RFID_Reader.h”, in a similar fashion to the SoftwareSerial, by including the library.

7.3.2 Setup Function

This is the most basic function of any Arduino Software that is almost always created first, but always accessed and executed first. In this function, we will be activating the Serial at a specific baud rate so that it can be used to interface with the rest of the hardware. We will be setting up the region that the RFID reader will be used in to obey FCC regulations. Also, we will set the amount of read power applied to the RFID reader, this is passed through as an integer value corresponding to the amount of power rated in dBm.

7.3.3 Loop Function

This function is exactly as it sounds, made to continuously run an infinite amount of times so long as the unit has power applied. The code within this function must be written in such a way to facilitate smooth executing given the looping nature. All of the active sub-functions we write should be called in this section, for example, we will be calling the ReadTags function that is written by us.

7.3.4 ReadTags Function

This function is integral to the success of our project. The function itself will command the RFID reader to read, for a small amount of time, the surrounding RFID tags within reading range. This function has no inputs and will return the ID numbers of the tags read with their respective relative signal strength.

7.3.5 SortTags Function

This function takes the input of the relative signal strength values that are obtained from the ReadTags function, then sorts them according to the signal strength from greatest strength to least strength in dBm. This output is returned and can be used by another function.

7.3.6 IsGood Function

This function takes part of the output of the SortTags function, then using an algorithm, references the relative signal strength readings and calculates if the RFID tag is ready to be scored. This means whichever beanbags have successfully landed on the gameboard or have fallen into the 3 point hole, will be eligible for counting towards score. The input here is the tag ID, and the output is a Boolean.

7.3.7 DoScore Function

This function takes the output of the SortTags function as its input. Using this function with the IsGood function together, it calculates the score of both teams. This function is called after receiving the physical button input from the Console via Xbee. The score is calculated all at once with differentiation between 1 and 3 points via the IsGood function. With all the calculations done, it returns the score of both teams.

7.3.8 DoXbee Function

This function sends the current state of the game across the Xbee wireless connection. It's the score of the first team prefixed by the characters corresponding to the color of their bean bags, followed by the score of the second team with the same condition.

7.4 Major Hardware Components

Here we have the major components for our project build. At the top left, we have a driver for our audio speaker setup, the 12-volt 3500 mAh battery, and our ATmega2560 chip on a breakout board. Top right, we have the power switch, the audio amplifier setup, and physical pushbuttons. Below the ATmega2560 chip, we have one of our voltage regulators, the Xbee explorer, FTDI USB breakout board, our two Arduino dev boards, the RN-52 Bluetooth module, the M6E Nano RFID reader module, two 1mW Series 1 Xbee modules, two Xbee shields, and our seven-segment displays. Lastly, on the bottom right, we have our EPC gen2 RFID tags, and an assortment of resistors.



Figure 28: All Major Parts

8.0 Administrative content

In this section, the project milestones and budget will be discussed in greater detail. The milestones will be the timeline of when group and personal goals wanted to be met. The budget discussion will hold information on how much each item would actually cost in the end and how money was obtained to purchase all the materials as well as any monetary constraints.

8.1 Milestone Discussion

Objective	Dates Start – End		Status
Senior Design I			
Group selection (first meeting)	1/19/17	1/19/17	Completed
Project Ideas	1/19/17	1/26/17	Completed
Idea selection	1/26/17	1/27/17	Completed
Initial Documentation	1/27/16	2/3/17	Completed
Table of contents	2/3/17	3/24/17	In progress
60 pages	2/3/17	3/31/17	Completed
100 pages	2/3/17	4/14/17	Completed
Goal for Documentation: 3 pages/week to meet 30page deadline each			
Final Document	2/3/17	4/27/17	In progress
Research and Design			
Research design implementation	2/2/17	N/A	In Progress
Cost of design	2/2/17	N/A	In Progress
Power supply	2/2/17	N/A	In Progress
PN532 RFID controller shield	2/2/17	N/A	In Progress
High Frequency RFID reader	2/2/17	N/A	In Progress
PCB layout	2/2/17	N/A	In Progress
Senior Design II			
Build Prototype	4/27/17	5/16/17	In Progress
Testing	4/2/17	TBA	In Progress
Peer Presentation	TBA	TBA	To be completed
Final Report	TBA	TBA	To be completed
Final Presentation	TBA	TBA	To be completed

Table 26: Timeline

8.2 Budget Discussion

Table 27: Budget

Status			
Purchased			
Not Purchased			
Part Name	Quantity	Cost (Each)	Cost (Total)
Arduino MEGA 2560 Microcontroller	2	\$35.46	\$70.92
Simultaneous RFID Reader - M6E Nano	1	\$199.99	\$199.99
UHF RFID Tag - Adhesive	10	\$0.30	\$3.00
400-point Experiment Breadboard	1	\$6.47	\$6.47
Xbee Shield Module for Arduino	2	\$11.97	\$23.94
XBee 1mW Wire Antenna	2	\$26.95	\$53.90
XBee Explorer USB	1	\$24.95	\$24.95
Push Button Switch	1	\$1.95	\$1.95
7-Segment LCD Displays	4	\$8.00	\$32.00
LED Strips	1	\$12.00	\$12.00
Custom PCB	2	\$30.00	\$60.00
12v Battery	2	\$25.00	\$50.00
12v Battery Charger	1	N/A	\$0.00
Arduino Stackable Header Kit - R3	1	\$1.50	\$1.50
USB Cables	2	\$5.00	\$10.00
Bluetooth module & Breakout Board	1	\$44.95	\$44.95
FTDI Basic Breakout 3.3v	1	\$15.95	\$15.95
FTDI Basic Breakout 5v	1	\$9.95	\$9.95
Male Header Pins	1	\$5.39	\$5.39
3" Speaker	2	\$3.50	\$12.50
LM1084 Voltage Regulators	3	\$3.00	\$15.99
LM386 Audio Amps	2	\$8.00	\$16.00
Xbee Breakout Board	1	\$4.99	\$4.99
Toggle Switches	2	\$1.50	\$3.00
Power Jack	2	\$1.50	\$3.00
2560 chip	1	\$19.50	\$19.50
Breakout board for chip	1	\$30.75	\$30.75
ATMEGA 2560	1	\$11.99	\$11.99
SOLERING WIRE	1	\$3.50	\$3.50

The above Table is the list with all the materials we need for the project there is also a key letting one know that parts in green have been purchased while the

parts in red still need to be purchased. Other information the table shows are the quantity that is needed of each item, the cost of each item and then total cost with shipping included that is why some values don't add up visually. Since some items had free shipping or bought all together and shared a shipping cost.

This list of parts on the budget are not final, and is subject to change as the project progresses. A thorough account of every component purchase is carefully kept. As of the time this is being written this is the list but that may change if parts don't perform up to standard or better options are discovered. The total cost of the components will be split evenly between the group members. The Smart Cornhole project is self-funded as of 4/14/17 no investors have agreed to fund all or part of the project. Different incentives have been proposed to help get investments such as publicity with company logo on the Cornhole board.

8.4 Project Design Problems

It is often said., to succeed you must fail. Our senior design project is fun and challenging. During the creation of Smart Cornhole design there were several problems, most of the major problems have been addressed and was rectified to implement a successful project. Below are the few problems that occurred during the implementation of the project.

8.4.1 ATMEGA 2560 CHIP Soldering Problem

The ATmega2560 chip is a chip from Arduino MEGA 2560 board that we are using to implement our own customized PCB. To implement our design, we must order just the chip from the board and test it according to our designed schematics. So, the necessary chip was ordered and delivered on time. When we received the chip, it was tiny. Moreover, it required highly skilled soldering technique to solder it on the customized prototype PCB that was designed just to test that chip. The problem here was no one in our group was highly skilled nor had an appropriate equipment to solder the chip on. This problem set us back few days on implementing our testing. We finally decided to give it a try to solder ourselves, after the few attempts we failed miserably. In addition, we bridged some of the pins and destroyed one chip.

After our failed attempts, we started looking around for additional help. We researched on the internet for a newer chip which has already been soldered, but unfortunately, we did not find any. We asked fellow students for help, which brought us to the conclusion that it will require a professional help and professional equipment. Finally, one of the group member reached out to his co-worker, who was highly skilled in that field. The chip was soldered on and was ready to be tested.

8.4.2 Bluetooth Speaker Noise Problems

As previously mentioned, our project is fun and challenging. The entertainment side of our project requires an additional subsystem of wireless speakers. The necessary speakers and Bluetooth board was bought. It was delivered on time and was ready to be tested. We successfully implemented the test and Bluetooth connection with our mobile device. The problem here was when we played the music the speakers were not loud enough to hear. So, we did the research on the how to sort this problem, even though we already had an idea that it will require an op amplifier to resolve our problem. So, we added an op-amp that was given to use for our class-lab. We just tested it around to if the sound get better and louder. After the few test, we successfully implemented the loud enough sound but it had too much noise. This problem was noted and was researched. We came to conclusion that it requires an audio amplifier. We ordered the necessary amplifier and was able to achieve the clear loud audio when it was connected to Bluetooth module.

8.4.3 Software Development Problems

When we were developing the code for the microcontroller, we ran into several problems that arose from compatibility of different Arduino Software versions. One of the major conflicts was the compatibility of the Arduino Library for the M6E Nano RFID reader. The library was not natively compatible for the latest Arduino Software version 1.8.2, so we needed to modify the library to be compatible for the newest version. The problem lies within the way the newest Arduino Software processes unsigned characters for the compiler. This required us to go into the M6E Nano library and changing the way an unsigned character is referenced.

Another problem that we encountered while developing on the newest Arduino Software version is the SoftwareSerial. It was not playing nice with the pins we desired to use. In this case we essentially changed the default pins being used for the SoftwareSerial for the RFID reader and the Xbee module. By choosing different pins for each of the two, we avoided the Serial conflicts.

The last major problem we encountered while developing the software is the algorithm that we used to determine which RFID tags were scored as 3 points or 1 point. We were using Relative Signal Strength Indication, so all we had to work with was the relative signal strength and not actual distance. We initially used a basic algorithm to determine which tags were close and which were far, but this algorithm proved to be flawed and not good for use in the final software. We switched algorithms to a new faster and more reliable one. This allowed us to accurately detect whether the beanbags fell through the hole, landed on the game board, or were completely out of play.

9.0 Conclusion

In closing, the Smart Cornhole team is excited to pursue this endeavor. The entire project is based on the largest pitfall of playing a regular Cornhole game, which is inaccurate tracking of the score of both teams due to external circumstances such as lack of attention, since there are usually many distractions in environments where Cornhole is played. The concept of Cornhole is to have a slanted game board where teams have sets of beanbags that are to be thrown from a distance of about 27 feet toward the board. The basic rules of the game state that the players must throw and land their beanbags either in the hole, to receive 3 points, or on the board to count as a single point towards their teams score. The winning team is determined by an exact count of 21 points, going over the count of 21 in a round will result in a deduction.

The team saw many products and projects that were Cornhole related, but did not have all the features we wanted to implement. Such projects include implementations that have lighting effects, audio capability, and automatic scoring. While these concepts are new and exciting, they are mediocre as the lone selling point of a project. We decided that we would implement not just a couple of these technologies, but all of them. Our cornhole implementation will not only include precise automatic scoring, but also aesthetics (in the form of lighting), speakers with Bluetooth Audio capability, wireless communication, low power draw, and a long lasting rechargeable battery.

As a collective, we did extensive research on which components we would consider using for the project build. For the detection of the beanbags, there was a clear winner in the technology we chose to use, which is Radio Frequency Identification. We ended up choosing the M6E Nano RFID Reader Module, it's accurate, simple in concept, has a lot of function, and fits our power requirements. For a microcontroller, we chose to go with the ATmega2560, this chip is fast, has a wide array of programmable function, is low in cost, and fits our power requirements. The wireless communication we will be using is Xbee, or ZigBee, which is an implementation of a Personal Area Network. The Xbee modules are 1mW Series 1 modules which have excellent range and bandwidth specifications. The power, will be provided by a 12-volt 3500 mAh battery, this is the perfect combination of capacity, efficiency, and cost. Our Bluetooth implementation uses the RN-52 Bluetooth Module, this module is compact and draws little power. The score will be displayed on a seven-segment display setup with tri-color displays manufacture red by ChromeLED, and driven by seven-segment decoders. The lighting effects will be in the form of 3258 LED strips from MENZO.

We will be creating only one of the two gameboards for actual play. We, as a team, chose to display proof of concept for two game boards by creating a "Console", which is a standalone island-style tower that is in constant wireless

communication with the main game board; constantly staying updated with the scoring, and capable of sending commands back. This console sits 27 feet away from the game board, has drink holders, and also serves as the standing point for both teams when throwing beanbags at the game board. The console has the same microcontroller and wireless setup as the game board, and includes a physical switch for controlling certain aspects of the game.

10.0 Team Description and Delegations

The Smart Cornhole team consists of three electrical engineering and one computer engineering student. By combining two different areas of engineering we can successfully implement our project. This is often seen at workplace, where different fields of engineers work together to design, implement, test and deliver the assigned project/product either by a company or a customer. These classes are often designed to implement and collaborate our knowledge as a group which was acquired from coursework.

Nihil Patel, is an Electrical Engineering student who has experience in circuitry design as well as great leadership skills. Throughout his engineering studies he has learned all about the core studies of Electrical Engineering. In his free time, he really enjoys working out, cooking and tailgating at games, hence the idea of Smart Cornhole. He has been involved with social clubs such as IEEE, SHPE and NSBE. In Society of Hispanic Professional Engineers (SHPE), where he is an outreach ambassador for Valencia College. He has worked for Walt Disney World for 4 years where he gained successful experience in guest service, problem-solving, planning/implementing proactive procedures, and being a great team player. He has learned many skills that are beneficial to this project. These skills will be beneficial during the testing, implementing and designing the schematics for the PCB as well as the final presentation of the project.

Giovanni Lara, has been an Electrical Engineering student at the University of Central Florida for the past two years. He is passionate about this career since he was a young child. Throughout his studies he has learned to review and design schematics for different applications. The experience in working with schematics will help to design the schematic for the PCB as well as reviewing it for any discrepancies. Furthermore, he is a member of the Honor Society of Electrical and Computer Engineers (IEEE-HKN), and the National Society of Leadership and Success ($\Sigma\Lambda\Pi$).

Alex Lam is a Computer Engineering student who has had a great interest in computers since he was a young age. Throughout his undergraduate career, he has studied about all facets of computer hardware down to the silicon and transistor design. Within the Smart Cornhole project, he is mainly working on the software and its integration into the design. The majority of the contribution would be his expertise in development and debugging, as it relates to software engineering, specializing in the programming of microcontrollers. He will be developing the software on the development boards to be finalized into the last iteration of design when the microcontroller is soldered into a printed circuit board. Paired with his Electrical Engineering teammates, he can focus solely on development, without the burden of the Electrical Engineering technical knowledge that Computer Engineering Undergraduate curriculum does not sufficiently provide.

Francisco De La Cruz, is another Electrical Engineering student who is currently in an internship which has been very helpful in bringing knowledge from the real engineering world. Thru, his internship he has learned how to properly solder, read and understand schematics, troubleshooting to identify what is causing errors, and various other task. For senior design 1 the skills of soldering and reading schematics were implemented. Research included Xbee and also some power calculations to find out how much power is being consumed to decide what battery was necessary for the project. In senior design 2 it is better no errors are found but if there, are his new skills of testing for errors and fixing them may come in handy.

11.0 Appendices

11.1 References

[1] Power Supply Safety Standards, Agencies and Marks. (n.d.). Retrieved March 13, 2017 from <http://www.cui.com/catalog/resource/power-supply-safety-standards-agencies-and-marks.pdf>

[2] 802.15.4-2015 - IEEE Standard for Low-Rate Wireless Networks. (n.d.). Retrieved March 13, 2016, from <https://standards.ieee.org/findstds/standard/802.15.4-2015.html>

[3] Soldered Electrical Connections. (n.d.). Retrieved March 14, 2017 from <https://snebulos.mit.edu/projects/reference/NASA-Generic/NASA-STD-8739-3-2.pdf>

[4] Top 3 Standards for Lithium Battery Safety Testing. (n.d.). Retrieved March 16, 2017 from <http://www.metlabs.com/battery/top-3-standards-for-lithium-battery-safety-testing/>

[5] Official Cornhole Rules by the ACO. (n.d.). Retrieved March 16, 2017 from <https://americancornhole.com/aco-official-rules-for-the-sport-of-cornhole/>

[6] Understanding UL 94 Certifications and Limitations. (n.d.). Retrieved March 16, 2017 from http://www.ul.com/wp-content/uploads/2014/04/ul_UL94CertificationsAndLimitations.pdf

[7] Bluetooth Core Specification. (n.d.). Retrieved March 21, 2017 from <https://www.bluetooth.com/specifications/bluetooth-core-specification>

[8] ThingMagic Nano Design Guide. (n.d.). Retrieved April 1, 2017 from https://cdn.sparkfun.com/assets/learn_tutorials/6/1/3/Nano_Design_Guide_rev01E.pdf

[9] "Cornhole." *Wikipedia*. Wikimedia Foundation, 31 Mar. 2017. Web. 15 Apr. 2017.

[10] "Official Cornhole Rules | How To Play Cornhole | American Cornhole Association (ACA)." *Cornhole, Corn Hole, Corn Toss, Bean Bag Toss and Bean Toss*. N.p., 31 Mar. 2017. Web. 15 Apr. 2017.

[11] "Intelligent Cornhole Board (ICB)." *Http://ece.citadel.edu/skinner/wp-content/uploads/2016/08/ICB.pdf*. N.p., n.d. Web. 15 Apr. 2017.

[12] "Cornhole /Bags Electronic Scoring System." *Https://courses.engr.illinois.edu/ece445/getfile.asp?id=5201*. N.p., 12 Feb. 2012. Web. 31 Mar. 2017.

[13] "Self scoring bag toss." *Seniordesign.ee.nd.edu/2007/Design%20Teams/America/Final_Report.doc*. N.p., 12 Feb. 2012. Web. 31 Mar. 2017.

[14] McCall, Hayden. "Built In Bluetooth Speakers." *West Georgia Cornhole*. N.p., 28 Aug. 2015. Web. 31 Mar. 2017.

[15] "Orlando Florida Party Rental Showcase." *Orlando Florida Party Rentals- - Party Rentals Orlando*. N.p., n.d. Web. 31 Mar. 2017.

[16] "Proximity sensor." *Wikipedia*. Wikimedia Foundation, 11 Apr. 2017. Web. 31 Mar. 2017.

[17] "Voltage regulator." *Wikipedia*. Wikimedia Foundation, 22 Mar. 2017. Web. 31 Mar. 2017.

[18] "Light-emitting diode." *Wikipedia*. Wikimedia Foundation, 11 Apr. 2017. Web. 31 Mar. 2017.

[19] "Battery (electricity)." *Wikipedia*. Wikimedia Foundation, 11 Apr. 2017. Web. 31 Mar. 2017.

[20] "Wireless." *Wikipedia*. Wikimedia Foundation, 07 Apr. 2017. Web. 31 Mar. 2017.

[21] "Image processing." *Wikipedia*. Wikimedia Foundation, 29 Mar. 2017. Web. 31 Mar. 2017.

[22] "LED display." *Wikipedia*. Wikimedia Foundation, 07 Apr. 2017. Web. 31 Mar. 2017.

[23] "Loudspeaker." *Wikipedia*. Wikimedia Foundation, 23 Apr. 2017. Web. 31 Mar. 2017.

[24] LM10845-A Low Dropout Positive Regulators. (n.d.). Retrieved April 5, 2017 from <http://www.ti.com/lit/ds/symlink/lm1084.pdf>

[25] LM386M-1/LM386MX-1 Low Voltage Audio Power Amplifier. (n.d).
Retrieved April 5, 2017 from <http://www.ti.com/lit/ds/symlink/lm386.pdf>

11.2 Copyright Permissions

Bassuk, Larry Apr 24 (1 day ago) ☆
Dear Lara, Thank you for your interest in Texas Instruments. We grant the per...

Guillory, Michael <mguillory@ti.com> 11:53 AM (10 minutes ago) ☆ ↶ ▾
to me ▾

Hello Lara,
You may treat this email as official permission to use the requested schematic on page 1 of the document you reference below for your research paper. Please include the following text under the image in your paper: "Courtesy of Texas Instruments Incorporated". Also, any additional uses for the schematic will require separate requests.

Thank you for contacting TI and good luck with your paper.

Michael Guillory
Director, WW Corporate Brand Communications
Texas Instruments
mguillory@ti.com

 **TEXAS INSTRUMENTS**

Ti.com

From: Giovanni Lara [<mailto:gjolara1994@gmail.com>]
Sent: Sunday, April 23, 2017 2:02 PM
To: copyright@list.ti.com - Copyright Notice - Terms of Use
Subject: LM1084 Schematic copyright permission

Hello, I am an student of the university of central florida, currently working on a auto score detection cornhole. I am requesting permission to use your schematic for the adjustable regulator on my research paper from the LM1084 datasheet.

...

Soldered Connections Reproduce Image Request

instcomm@jpl.nasa.gov.

Soldered Connections Reproduce Image Request

Hello, I am an student of the university of central florida, currently working on a auto score detection cornhole. I am requesting permission to use one of the graphs on my research paper from

<https://npp.nasa.gov/docuploads/06AA01BA-FC7E-4094-AE829CE371A7B05D/NASA-STD-8739.3.pdf>

the figure is comfort zone found on page 6-1

Best Regards,
Giovanni Lara

Send | A | U | \$ | 🖼️ | 🔗 | 😊 | 🗑️ | ▾

Photo Permission



Charles Belekis <charles.belekis@gmail.com>

Sun 4/16, 10:59 AM



Sure.

Sent from my iPhone



Nihil Patel

Sat 4/15, 9:11 PM

charles.belekis@gmail.com; +2 more



Hello,

My name is Nihil Patel. I am a senior Electrical engineering student at university of Central Florida. I wanted to ask for your permission to use a photo of your product in my final year project documentation.

Move to ▾ Categories ▾ ... ↶ Undo

⌵

⌵



Trent Henkaline <trent@playcornhole.org>

Today, 12:03 PM

Nihil Patel

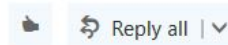

Nihil,

Yes, that's fine.



Nihil Patel

I have attached the picture in attachments. Here is link just in case. http:...

Sat 4/22, 2:32 PM



Trent Henkaline <trent@playcornhole.org>

Hello Nihil, Would you mind sharing the photo? Just want to make sur...

Wed 4/19, 3:13 PM

Photo Permission



Charles Belekis <charles.belekis@gmail.com>
Sun 4/16, 10:59 AM



Sure.

Sent from my iPhone



Nihil Patel
Sat 4/15, 9:11 PM
charles.belekis@gmail.com; +2 more



Hello,

My name is Nihil Patel. I am a senior Electrical engineering student at university of Central Florida. I wanted to ask for your permission to use a photo of your product in my final year project documentation.

▼ Sweep Move to ▼ Categories ▼ ... Undo

Us Custom Cornhole Request' page



Brandon Greba <sales@westgeorgiacornhole.com>
Mon 4/17, 11:13 PM

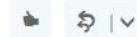

Sounds good

Cheers,

Brandon
West Georgia Cornhole
770-573-2507 Ext.701
[Website](#)
[Facebook](#)
[Instagram](#)



le Edit View History Bookmarks Tools Help

Mail - npatel35@knights... Contact Us // About ND /... Self-Scoring Console

https://www.nd.edu/about/contact/

Most Visited Getting Started Price Comparison User Dashboard GOOGLE

UNIVERSITY OF NOTRE DAME

RESEARCH INTERNATIONAL THE ARTS ATHLETICS SUPPORT ND ALUMNI

About Academics Admissions Faith & Service

will answer your question as quickly as possible or direct you to the appropriate office or department. To contact someone directly, visit our [people directory](#).

Notre Dame, Indiana 46556
Phone: (574) 631-5000

Security Police
(574) 631-5555

Mission Statement
Notable Alumni
Offices
Accessibility

I have a general question/comment

Name *
Nihil
First Last

Email Address *
npatel35@knights.ucf.edu

Comments *
Hello,
My name is Nihil Patel. I am a senior Electrical engineering student at university of Central Florida. I wanted to ask for your permission to use a photo of your product in my final year project documentation. This project was accomplished by senior students of University of Notre Dame in 2007-2008. Their team designed a new electronic scoring game.
http://seniordesign.ee.nd.edu/2007/Design%20Teams/America/Final_Report.doc

Submit

ENTERTAINMENT
Party Rentals Orlando.com

Facebook 407-284-1635
828-729-5392

Home Catalog Contact Us

Information
F.A.Q.
Contact Us

Categories
Airbrush Tattoo
Amusement Rides
Arcade Games
Bands/Music
Bleacher Rentals
Boogie Bodies
Bounce Houses
Bumper Balls
Bungee Jumps
Carnival Games
Carnival Prizes
Carnival Tents

Contact Us

Full Name:
Nihil Patel

E-Mail Address:
npatel35@knights.ucf.edu

Subject:
Photo permission

Enquiry:
Hello,
My name is Nihil Patel. I am a senior Electrical engineering student at university of Central Florida. I wanted to ask for your permission to use a photo of your product in my final year project documentation.

Thank You.

k | Sweep Move to Categories ... Undo

Photo permission 1

NP Nihil Patel
i have attached the picture in attachments. here is the link jus in case <http://www.pa...> Sat 4/22, 2:28 PM

BB Brian Baird <bbaird555@hotmail.com>
Which picture are you referring too? Sent by iPhone. Brian Baird Xtreme Entertainm... Fri 4/21, 8:58 AM